

Fast Loop Module

User's Manual

A Swagelok® Pre-Engineered
Subsystem

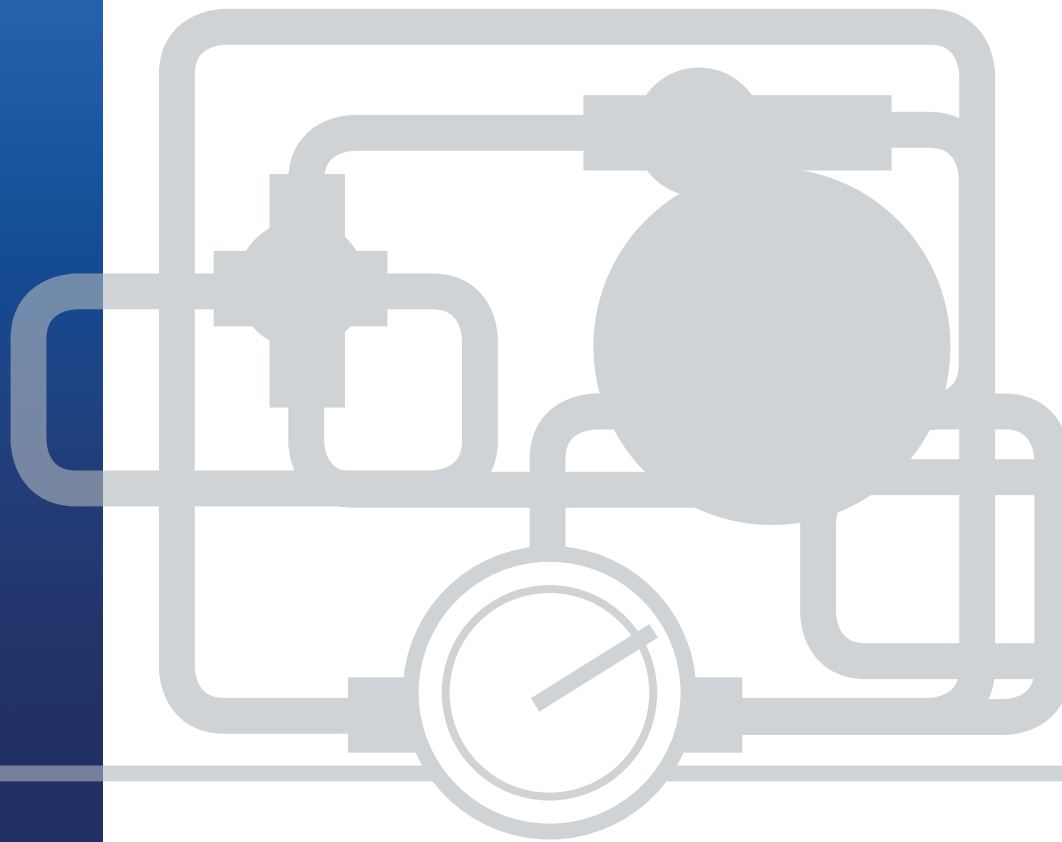

Only available through authorized
Swagelok sales and service representatives.

Swagelok®

Contents

Fast Loop Module System Manual	3
Introduction	4
Configurations	5
Mounting	10
Installation	12
System Startup	13
Operation	15
Maintenance	16
Troubleshooting	20
System Component User Instructions	24
Swagelok Instructions	
Swagelok Tube Fitting Instructions for 1 in. (25 mm) and smaller fittings, MS-12-01	24
Swagelok VCO Fittings Installation Instructions, MS-CRD-VCO	25
Packing Adjustment for 40 Series Ball Valves, MS-INS-40	27
Packing Adjustment for 40G Series Ball Valves, MS-INS-40G	28
R3A Series Externally Adjustable Relief Valve Maintenance Instructions, MS-CRD-0013	29
R4 Series Relief Valve Maintenance Instructions, MS-CRD-0048	36
Plug Valve Subassembly Replacement and O-Ring Rebuild Instructions, MS-CRD-0012	38
Repacking Instructions for N and HN Series Valves, MS-INS-N.	39
CH Series Check Valve Service Instructions, MS-CRD-0025	41
Tornado™ Instructions	
Tornado Model 601 Element Replacement Kit Instructions Element Kit Part #601-5TX	47
Tornado Model 601 Flow Screen Replacement Instructions Flow Screen Kit Part #601-6XX	49
Tornado Model 602 Maintenance Instructions	51

Only available through authorized
Swagelok sales and service representatives.

Fast Loop Module (FLM) System Manual

Swagelok

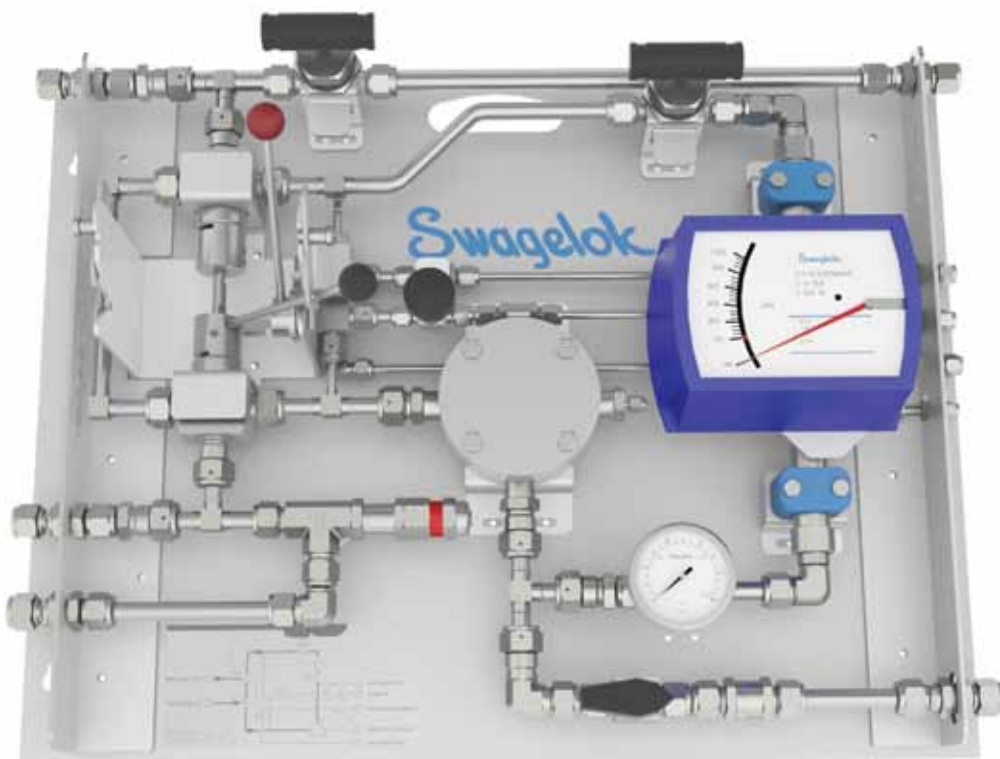

Configuration 4
1/2 in. Liquid System
with Optional Grab Sample and Relief Outlets Shown

Only available through authorized
Swagelok sales and service representatives.

Introduction

Fast Loop Systems are designed to handle high flows in sample transport lines to reduce time delays for online analyzer systems. Located at the analyzer and offering a bypass, the Swagelok® Fast Loop Module (FLM) can isolate the sample system and introduce a purge gas for system cleaning. The FLM extracts a sample through a filter while using the high flow rate of the fast loop to keep the filter element clean.

All FLM subsystems feature dual interlocked ball valves which enable the fast loop to be bypassed when the analyzer is not in service. This feature maintains flow through the fast loop system and improves overall system performance once the analyzer is back online.











Only available through authorized
Swagelok sales and service representatives.

A Swagelok Pre-Engineered Subsystem Fast Loop Module

Configurations

The FLM is available in four main configurations. See the *Fast Loop Module Application Guide*, MS-02-361, for additional information.

Configuration Symbols

	BV	Ball valve		NV	Needle valve - flow indicator
	CV	Check valve		PI	Pressure indicator
	FI	Flow indicator		PV	Plug valve
	FFL	Filter - fast loop		RV	Relief valve, (optional)
	NV	Needle valve - grab sample or purge outlet		SN	Snubber fitting-gauge protector (standard for liquid service)

Configuration 1: Base Module, Bypass Only

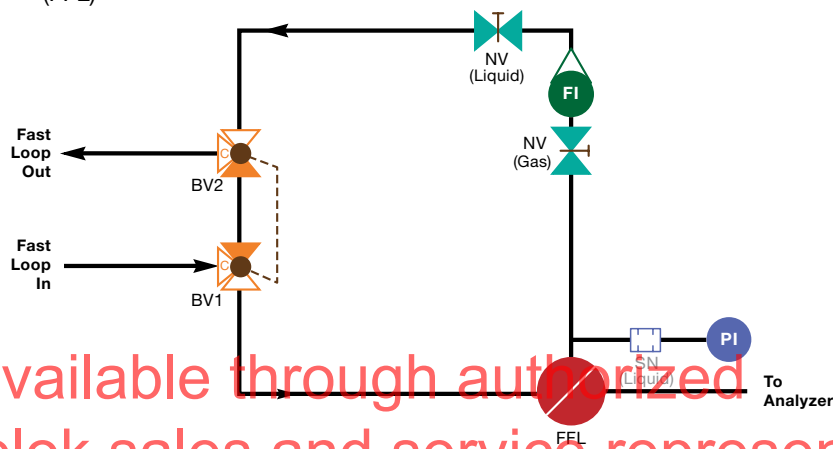
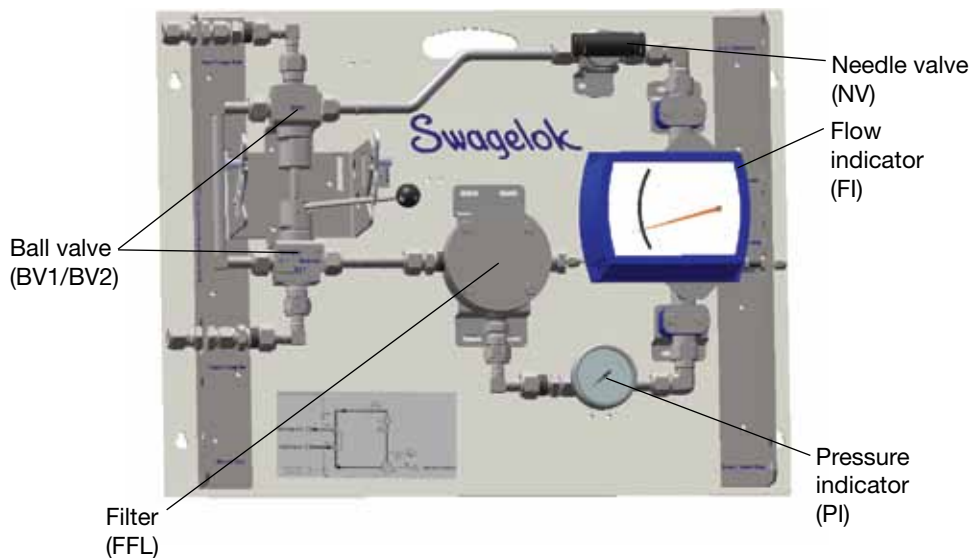

Only available through authorized Swagelok sales and service representatives.

Configurations

**Configuration 1: Base Module, Bypass Only
with Grab Sample and Relief Outlets Shown**

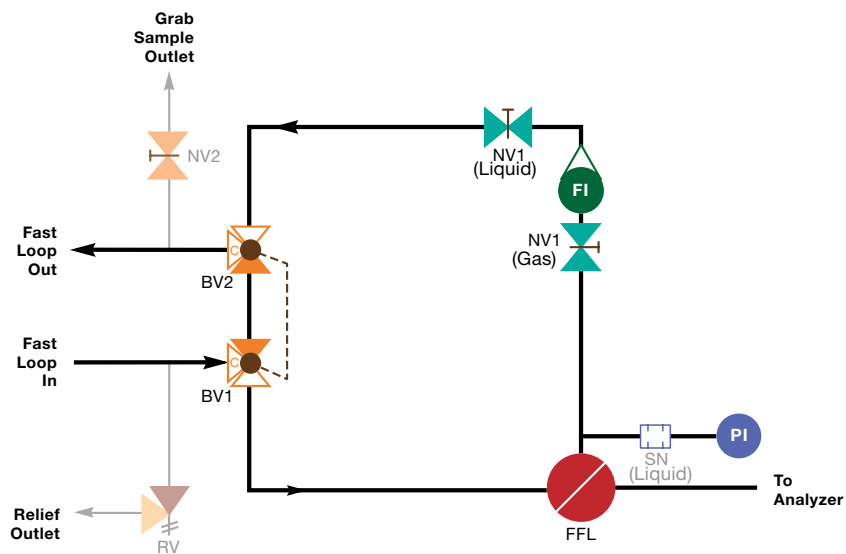
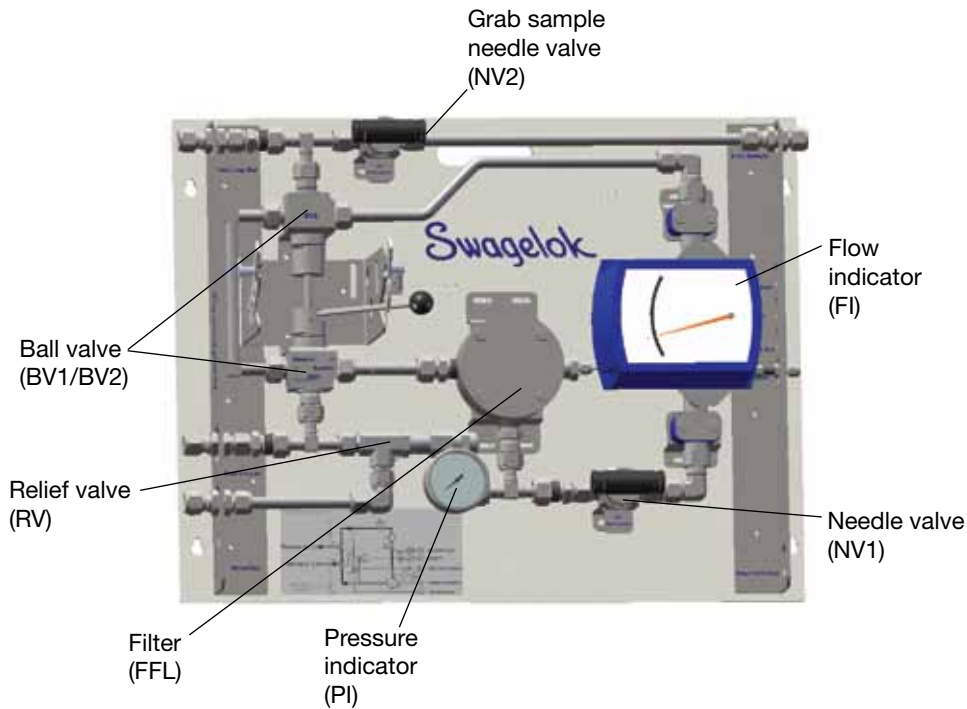

**Only available through authorized
Swagelok sales and service representatives.**

Configurations

Configuration 2: Return from Analyzer To Process

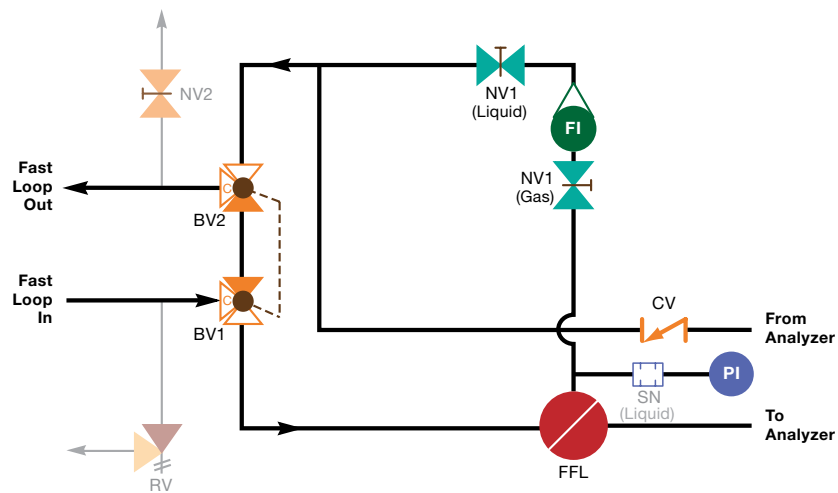
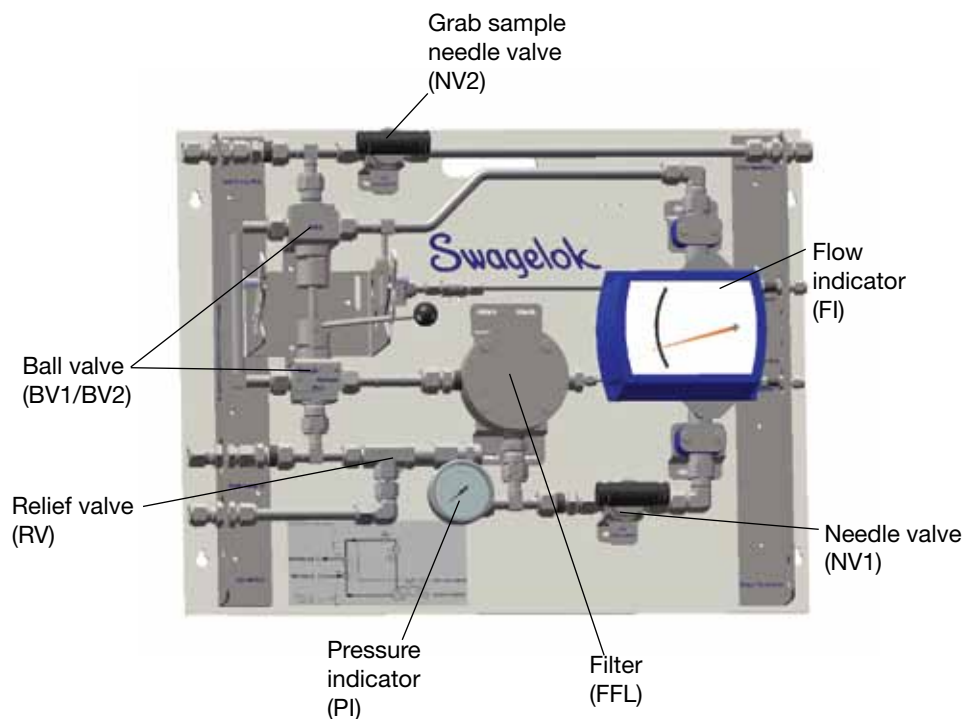

Only available through authorized Swagelok sales and service representatives.

Configurations

Configuration 3: Return from Analyzer Switch Drain

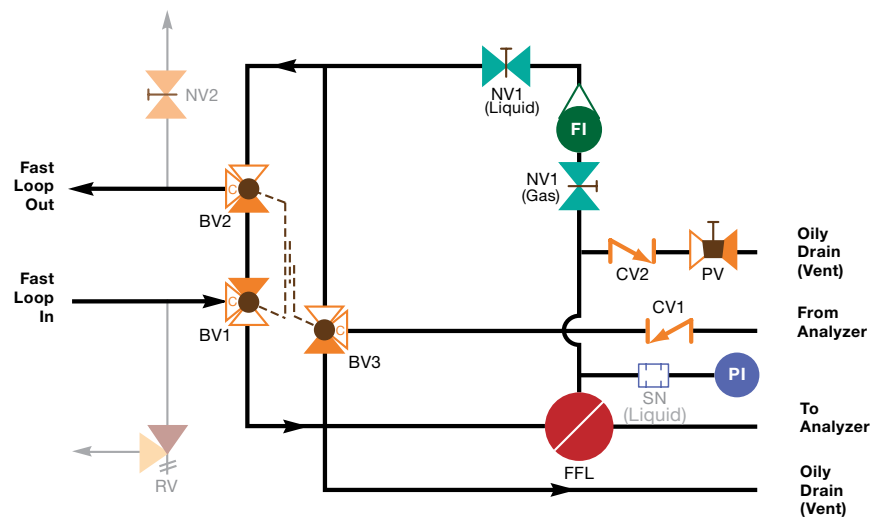
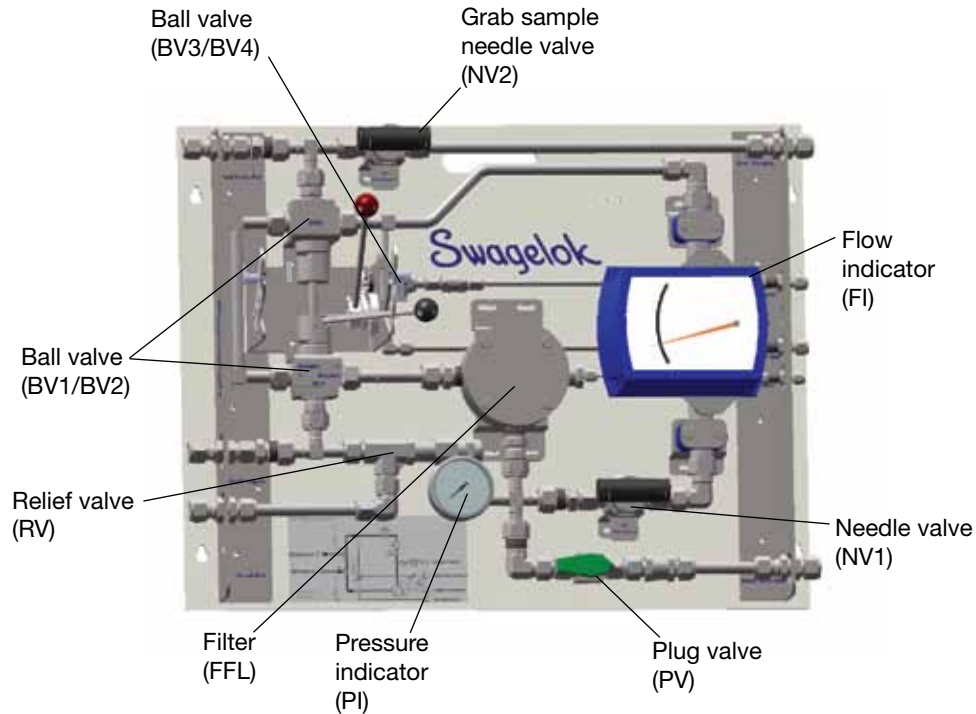

Only available through authorized Swagelok sales and service representatives.

Configurations

Configuration 4: Gas or Liquid Purge, Manual Drain

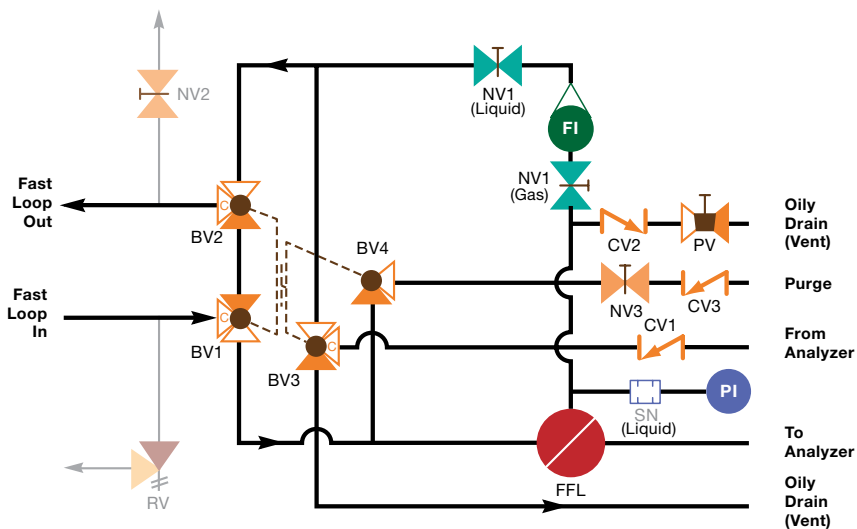
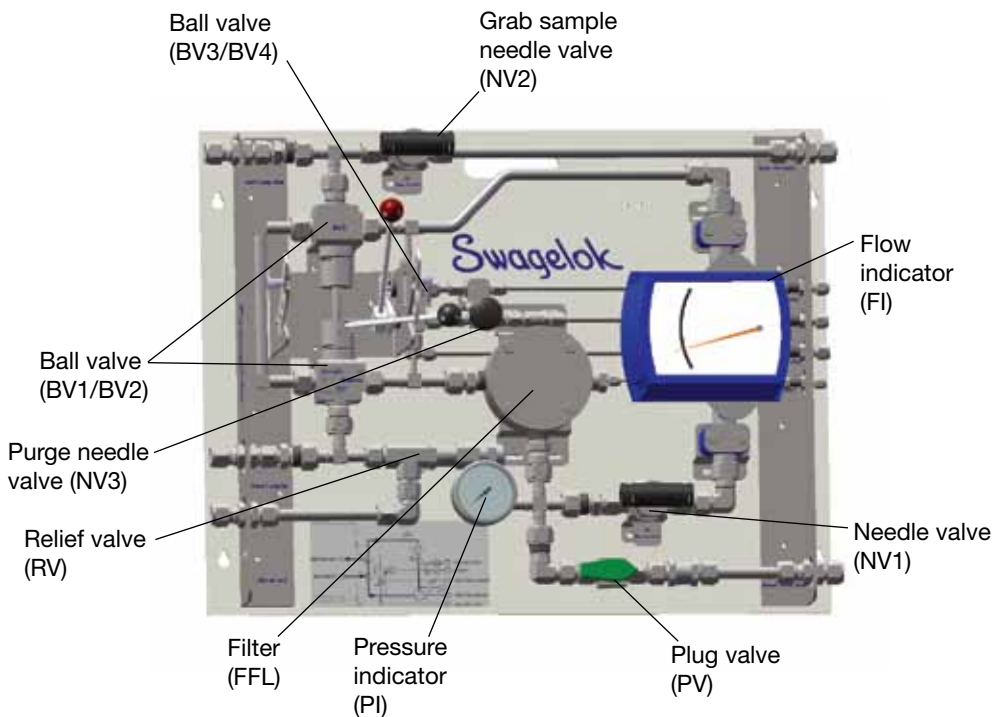

Only available through authorized Swagelok sales and service representatives.

Mounting

The FLM must be mounted to a vertical face or wall for function of the flowmeter and to allow for gravity to assist in draining the system. Mount the FLM as close to the analyzer inlet system or analyzer as possible.

The mounting holes are designed to fit over the bolt heads and assist in mounting. Attach with 1/4 in. fasteners with a maximum head size of 1/2 in. (not provided) in the four mounting holes on the plate.

The FLM is designed to flow with fast loop (process) connections on the left and the outputs to the analyzer on the right. System operation is not recommended in any other orientation.

Dimensions, in inches (centimeters), are for reference only and are subject to change.

1/4 in. Fast Loop Module

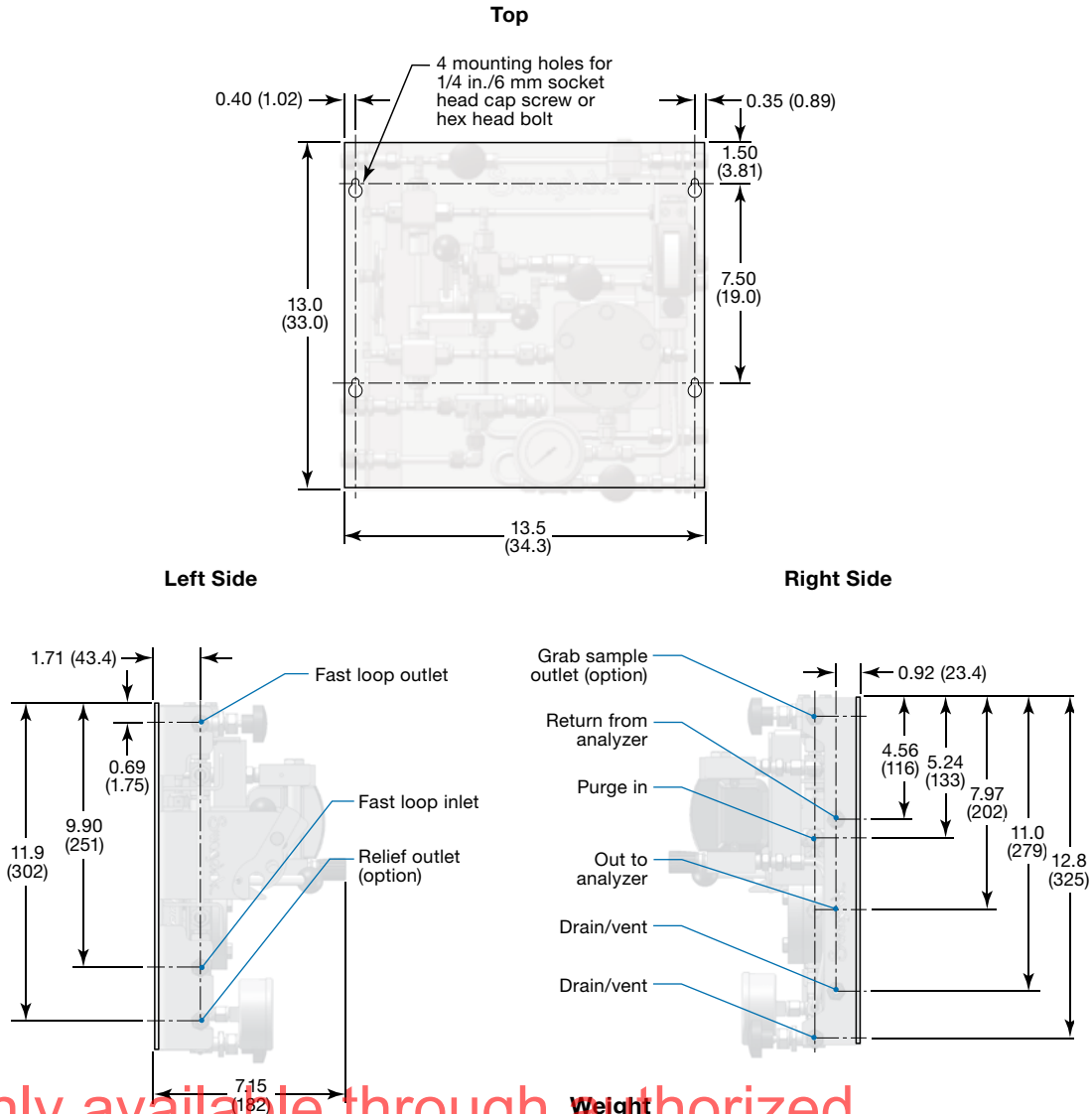

Weight
22 to 27 lb (10.0 to 12.2 kg)

Only available through authorized Swagelok sales and service representatives.

Mounting

1/2 in. Fast Loop Module

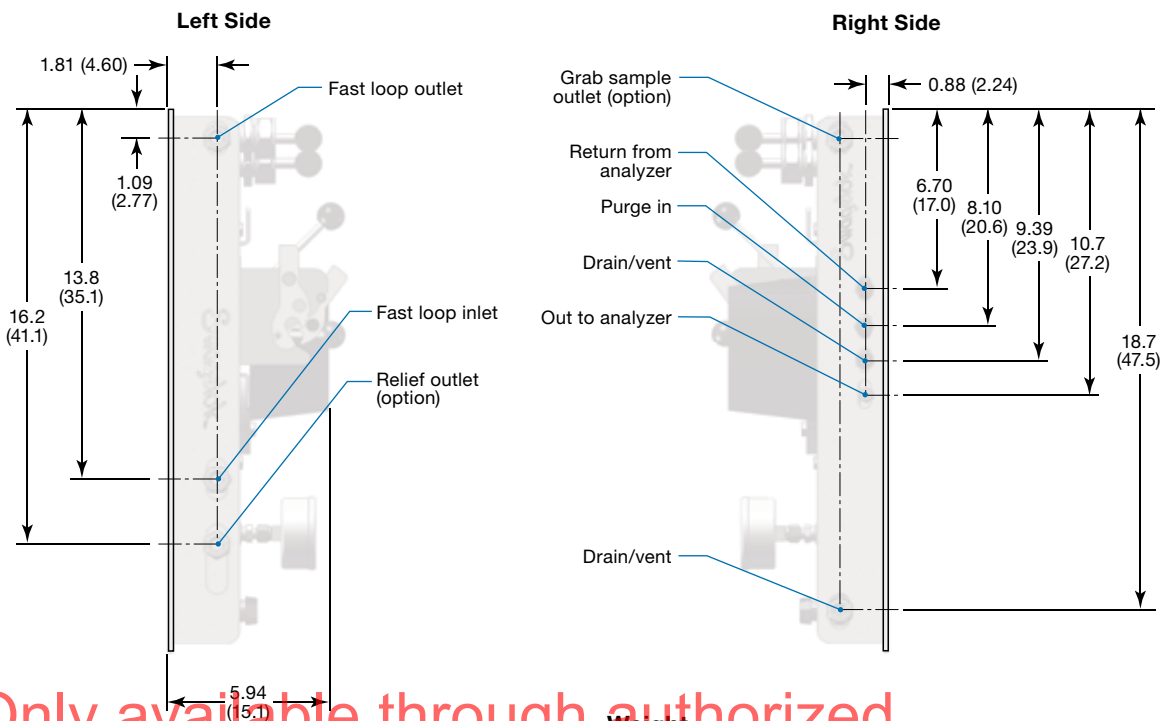
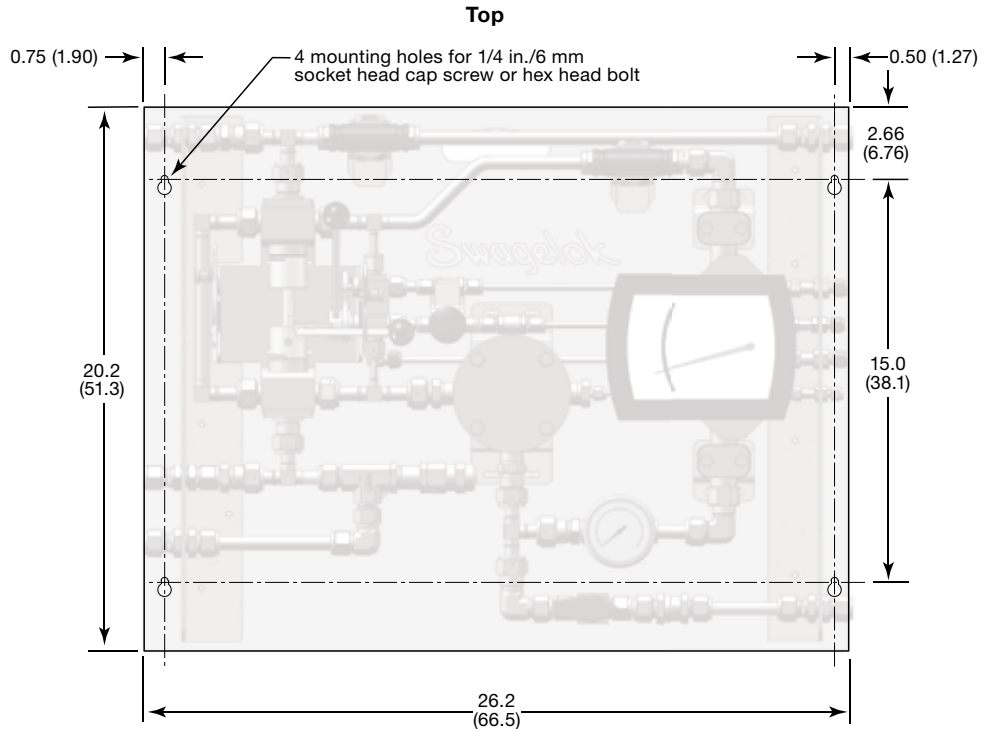

Only available through authorized Swagelok sales and service representatives.

Weight
65 to 75 lb (29.5 to 34.0 kg)

Installation

1/4 inch and 1/2 inch systems have fractional Swagelok tube fittings or metric Swagelok tube fittings for the system connections.

Note: For 1/4 in. systems, all inlet and outlet connections are 1/4 in. or 6 mm with the exception of the sample to analyzer connection, which is 1/8 in. or 3 mm.

Note: For 1/2 in. systems, the fast loop out, fast loop in, relief outlet, oily drain (bottom right), and grab sample outlet connections are 1/2 in. or 12 mm; return from analyzer, purge in, and oily drain (center right) connections are 1/4 in. or 6 mm; sample to analyzer connection is 1/8 in. or 3 mm.

Note: All internal fittings (non-system connections) are fractional fittings.

Install Swagelok tube fitting according to the *Swagelok Tube Fitting Instructions for 1 in. (25 mm) and smaller fittings*, page 24.

Inlet Connections

1. Fast Loop In - connect to the sample transport line to be analyzed.

2. Sample to Analyzer - connect to the remainder of the sample conditioning system prior to the analyzer.
3. Return from Analyzer (option) - connect to the outlet line from the analyzer. There must be sufficient pressure to create flow back into the FLM return.
4. Purge In (option) - connect to a purge line. It will be used to purge the sample side of the system prior to servicing.

Configuration 4 - The purge media may be either a liquid or a gas.

Outlet Connections

5. Fast Loop Out - connect to the return transport line. This line must be at lower pressure than the process supply line and is typically downstream from the sample point.
6. Relief Outlet (option) - connect to a sample disposal. This line will open if an overpressure event activates the relief valve.
7. Grab Sample Outlet (option) - connect to a grab sample unit to collect samples for analysis.
8. Oily Drain x 2 (Vent) (option) - connect to an oily drain or sample disposal suitable for the system media.

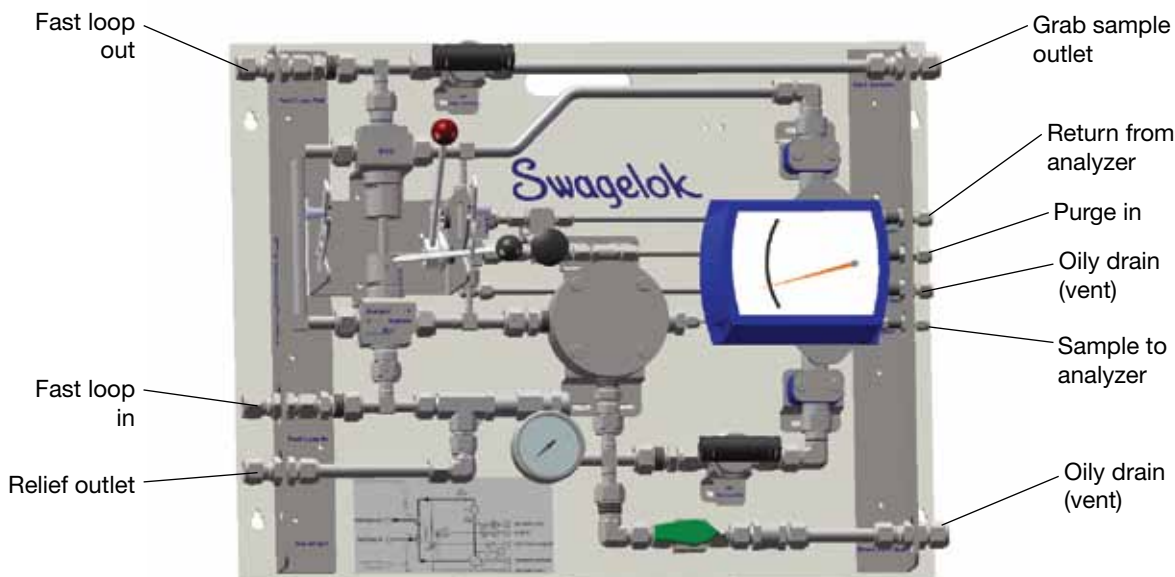

Only available through authorized
1/2 in. Fast Loop Module, Gas System, Configuration 4
Swagelok sales and service representatives.

System Startup

1. Place the FLM in bypass mode by moving the black handle (BV1/BV2) to the left.
2. Configurations 3 and 4 - Close the sample return valve by moving the red handle (BV3/BV4) to the up position.
3. Open flow to the FLM by opening all fast loop in, fast loop out, and process return lines. Since the FLM is in bypass mode, allow your system to run for a minimum of five minutes in order to flush the sample return lines.
Configurations 3 and 4 - verify the plug valve (PV) is closed.
4. Place the FLM in sample mode by moving the black handle to the right. Pressure will be shown on the pressure gauge (PI).
5. Adjust the flow to the desired rate.
1/4 in. systems - use the metering valve that is integral to the flowmeter.
1/2 in. systems -
 - Gas systems: use the needle valve (NV1) that is upstream of the flowmeter.
 - Liquid systems: use the needle valve (NV1) downstream of the flowmeter.

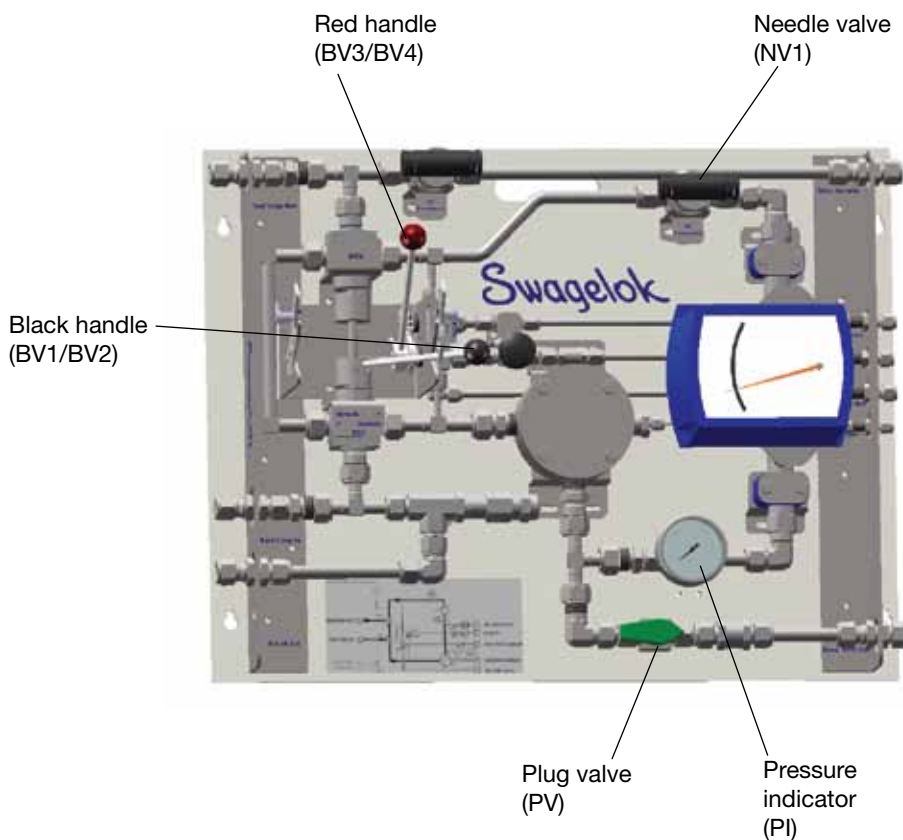

1/2 in. Fast Loop Module, Liquid System, Configuration 4

Only available through authorized
Swagelok sales and service representatives.

System Startup

6. Verify that flow is reaching the sample conditioning system downstream of the FLM.
7. Adjust the relief valve set pressure, if desired, according to the appropriate instructions.

Note: The relief valve is pre-set at the factory as specified in the ordering information.

1/4 in. - *R3A Series Externally Adjustable Relief Valve Maintenance Instructions*, page 29.

1/2 in. - *R4 Series Relief Valve Maintenance Instructions*, page 36.

Note: 1/2 in. systems with perfluorocarbon FFKM seals will contain R3A series relief valves.

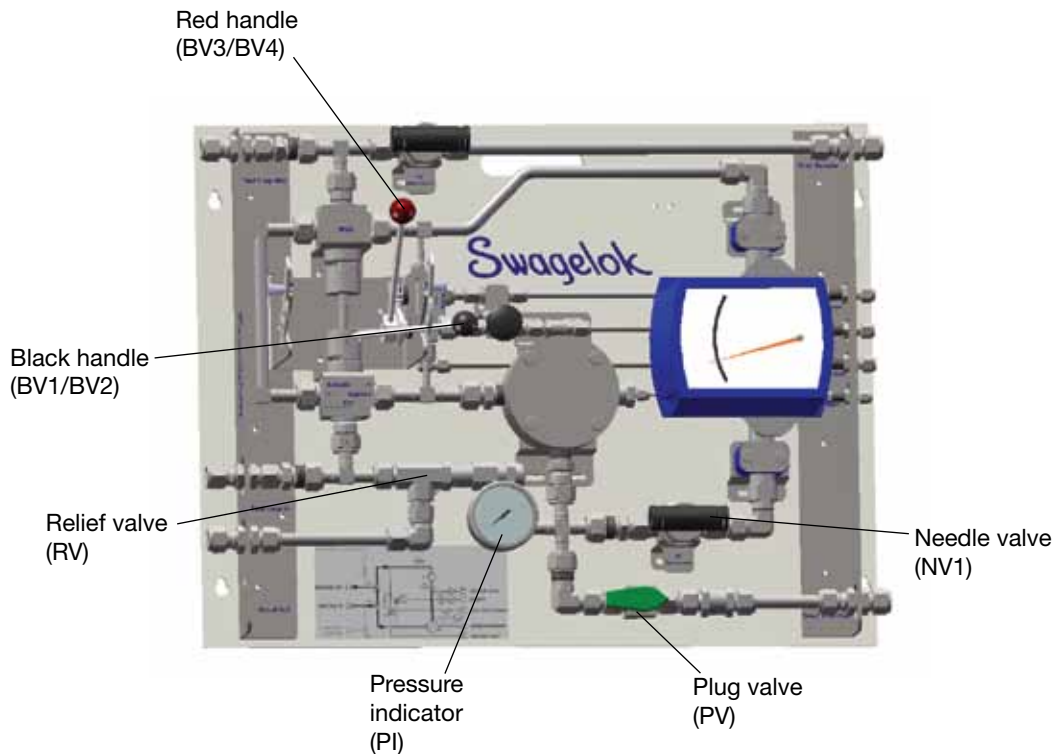

1/2 in. Fast Loop Module, Gas System, Configuration 4

Only available through authorized Swagelok sales and service representatives.

Operation

1. To place the FLM in sample mode, move the black handle (BV1/BV2) to the right. This will switch the flow to the sample side of the FLM.
2. To place the FLM in bypass mode, move the black handle to the left. This allows all FLM flow to bypass the sample side of the loop.
3. Configurations 3 and 4: To drain the system while in bypass, open the plug valve (PV). Configuration 3 systems may not drain completely. If more effective draining is required, Configuration 4 would be more appropriate.
4. Configurations 3 and 4: To place the system in drain/purge mode, move the black handle to the left to put the FLM in bypass mode. Then move the red handle to the down position to switch the analyzer return line to drain mode and opens the purge lines. (Purge lines are in Configuration 4 only.)
5. Configuration 4: To adjust purge flow, turn the handle of the purge needle valve (NV3), clockwise for less flow or counterclockwise for more flow.
6. To collect a sample from the grab sample outlet, open the needle valve (NV2).
7. To return the FLM to sample mode, reverse steps 1 through 3.



Failure to periodically inspect and maintain valve packing may result in leakage.



Swagelok ball valves are designed to be used in the fully open or fully closed position.

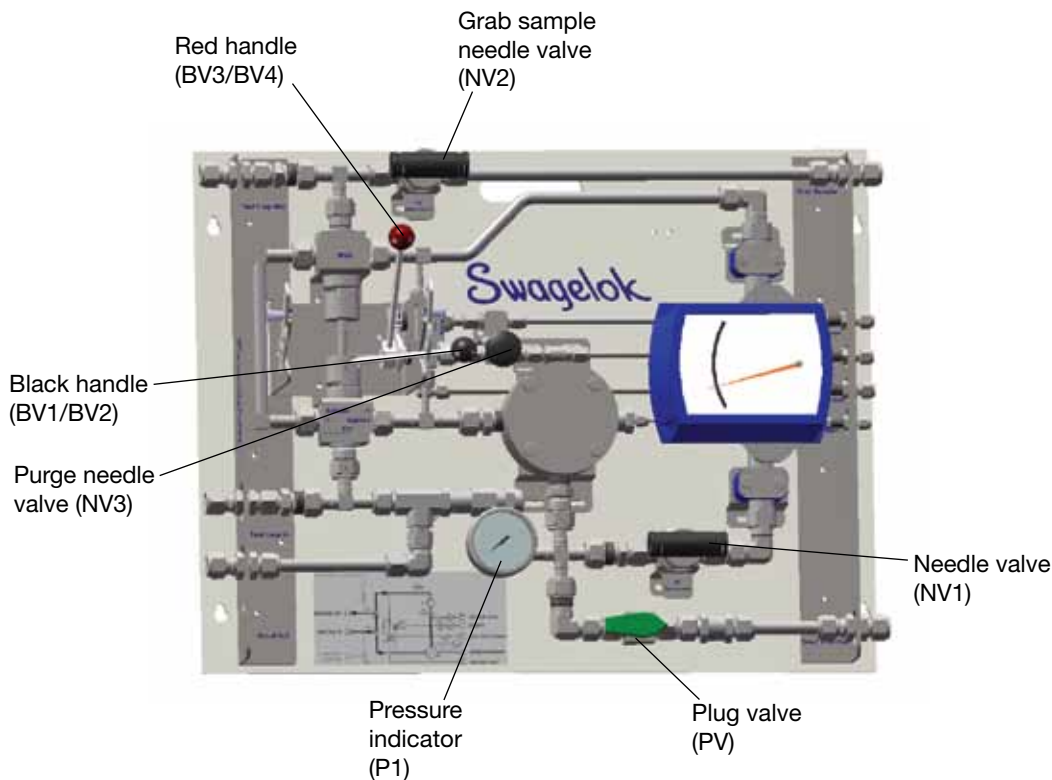

Only available through authorized Swagelok sales and service representatives.

Maintenance



Warning

Before servicing any installed system component you must

- depressurize the system
- purge the system (when possible).

Follow these steps to depressurize your FLM:

1. Place the FLM in bypass mode by moving the black handle (BV1/BV2) to the left. Fig. 1.
2. Configurations 1 and 2 - There is no direct method within the FLM to fully depressurize the system. Use external means to depressurize these configurations.
3. Configurations 3 and 4 - Place the system in drain/purge mode by moving the red handle (BV3/BV4) to the down position.
4. Configurations 3 and 4 - Open the purge valve (PV).
5. Configurations 4 - After a suggested minimum of five minutes, close the purge line by moving the red handle to the up position.
6. Verify that the FLM is depressurized by checking the pressure on the pressure gauge (PI).

Ball Valve Packing Adjustment

If a packing adjustment is needed on the 40 series ball valves (BV1/BV2 and BV3/BV4) it is not necessary to shut down or remove the system from service.

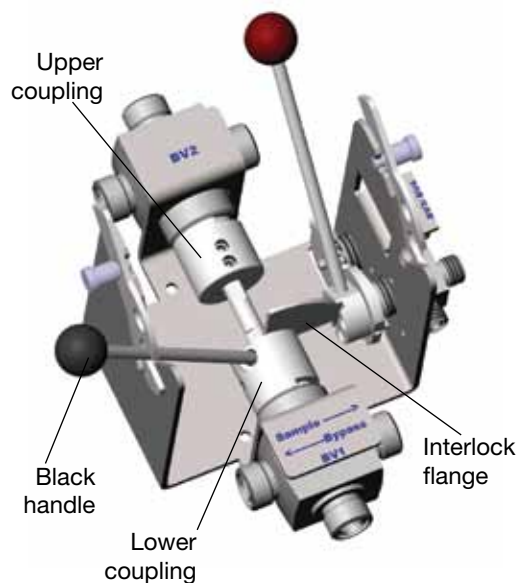

Fig. 1
System shown in Bypass mode.
Shown without tubing or system
connections for clarity.

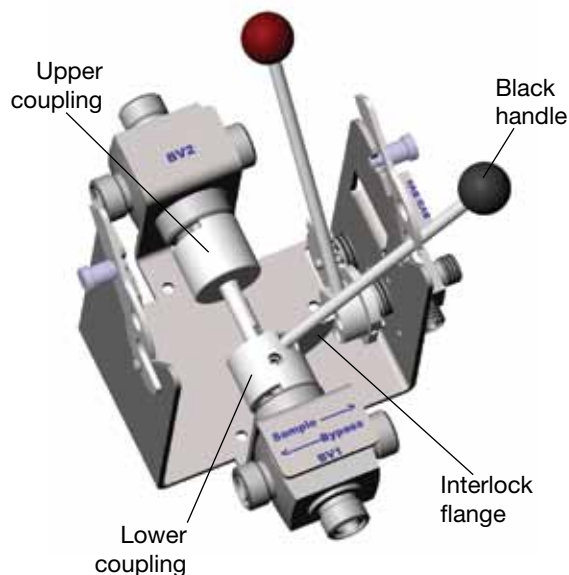

Fig. 2
System shown in Sample mode.
Shown without tubing or system
connections for clarity.

Only available through authorized Swagelok sales and service representatives.

Maintenance

To access the valve packing, you must remove the black handle subassembly:

1. Turn the black handle to the left to place the system in bypass mode. Fig. 1.
2. Configurations 3 and 4: Remove the interlock flange. Fig. 2.
3. Remove the black handle shaft by turning it counterclockwise. Fig. 2.
4. Loosen the two set screws on the upper coupling. Fig. 2.
5. Loosen the set screw on the lower coupling. Fig. 2.
6. Slide the couplings toward the center. Fig. 3.

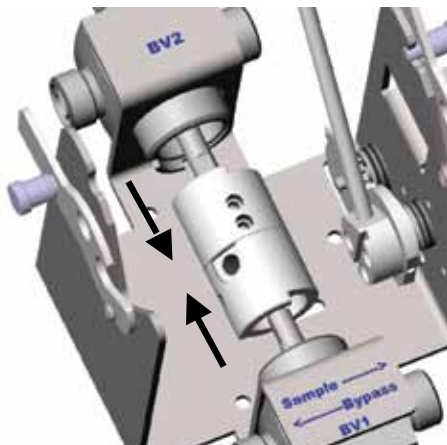

Fig. 3

7. Lift out the black handle subassembly. Fig. 4.

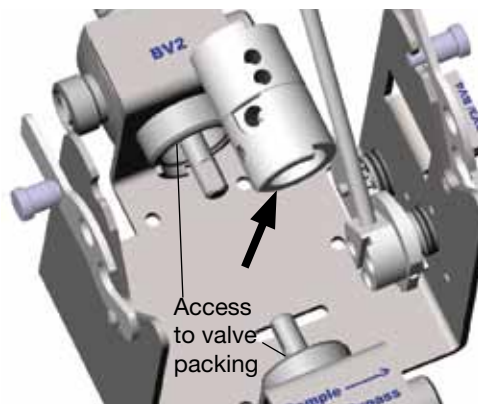

Fig. 4

8. Adjust the valve packing according to:
 - 1/4 in. - *Packing Adjustment Card for 40G Series Ball Valves*, page 28.
 - 1/2 in. - *Packing Adjustment Card for 40 Series Ball Valves*, page 27.
9. Configurations 3 and 4, To adjust the valve packing on the 40G valves:
 - Loosen the interlock set screws. Fig. 5.
 - Remove the interlock gears.

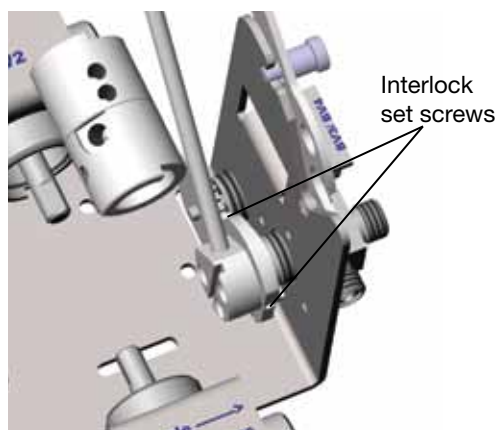

Fig. 5

Note: Configuration 3, only the lower gear must be removed.

- Adjust the valve packing according to *Packing Adjustment Card for 40G Series Ball Valves*, page 28. Fig. 6.

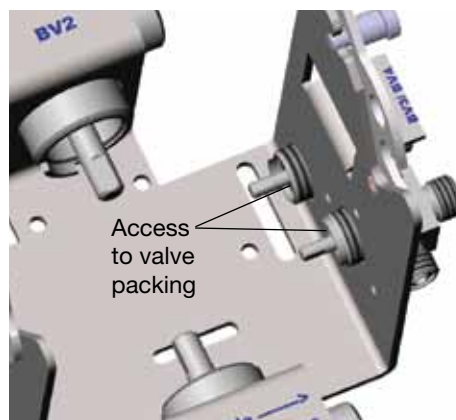

Fig. 6

Only available through authorized Swagelok sales and service representatives.

Reverse steps 1 to 8 to replace the handle subassemblies.

Maintenance

VCO® Fitting Maintenance

When required, maintain the VCO fittings within the system according to *VCO Fittings Installation Instructions*, page 25. Verify that the O-ring is in place when reassembling the fitting.

The locations of the VCO fittings within a Configuration 4 FLM are indicated in the drawing below.

Note: The VCO fitting locations may vary slightly between configurations.

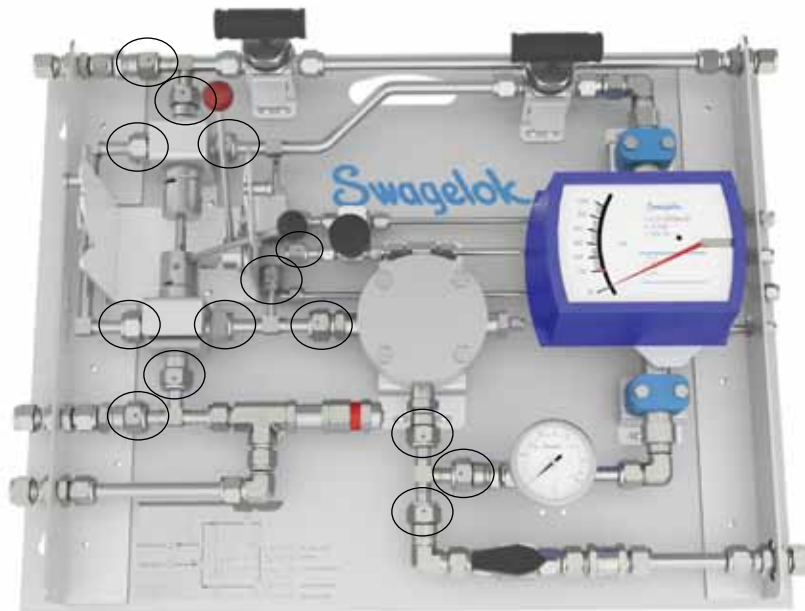

Configuration 4
1/2 in. Liquid System
with Optional Grab Sample and Relief Outlets Shown

Only available through authorized
Swagelok sales and service representatives.

Maintenance

System Component	Reference for Replacement Ordering Information
Proportional relief valve (1/4 in. FLM - R3A series, 1/2 in. FLM - R4 series)	<i>Proportional Relief Valves – R Series,</i> MS-01-141
Plug valve (1/4 in. FLM - P4T series, 1/2 in. FLM - P6T series)	<i>Plug Valves – P4T and P6T Series,</i> MS-01-59
VCO® fitting	<i>VCO® O-Ring Face Seal Fittings,</i> MS-01-28
Needle valve – flow indicator (1/4 in. systems - M1 series)	<i>Variable Area Flowmeters – G Series and M Series,</i> MS-02-346
Needle valve – flow indicator (1/2 in. systems - 12N series)	<i>Severe-Service Union Bonnet Needle Valves—N Series and HN Series,</i> MS-01-164
Needle valve – optional grab sample outlet (1/4 in. systems - 3N series, 1/2 in. systems - 12N series)	
Needle valve – optional purge outlet (3N series)	
Flow indicator (1/4 in. FLM - M1 series, 1/2 in. FLM - M3 series)	<i>Variable Area Flowmeters – G Series and M Series,</i> MS-02-346
Ball valve (40G or 40 series)	<i>One-Piece Instrumentation Ball Valves – 40G Series and 40 Series,</i> MS-02-331
Pressure indicator (PGI series, B model)	<i>Pressure Gauges, Industrial and Process— PGI Series,</i> MS-02-170
Check valve (CH series)	<i>Check Valves – C, CA, CH, CP, and CPA Series,</i> MS-01-176
Snubber fitting	<i>Pressure Gauges, Industrial and Process – PGI Series,</i> MS-02-170

Filter Kit Information

Module Size	Filter Type	Kit Type	Element Size		
			2 micron	10 micron	25 micron
			Ordering Number		
1/4 in. FLM	601 Filter	Gasket / Element Kit	601-5T2	601-5T10	601-5T25
		Flow Screen Kit	601-62SS	601-610SS	601-625SS
1/2 in. FLM	602 Filter	Element Kit	602-5T2-1	602-5T10-1	602-5T25-1
		5 Piece Element Kit	602-5T2	602-5T10	602-5T25

Only available through authorized Swagelok sales and service representatives.

Troubleshooting

Symptom	Cause	Remedy
Pressure indicator (PI) shows no pressure.	FLM is in bypass mode.	Place the FLM into sample mode by moving the black handle to the right. Check that both ball valves are turning when black handle is moved – if not, tighten set screws with valve in correct orientation.
	Fast loop is shut off.	Open all valves in fast loop line external to the FLM.
	The sample supply line is obstructed.	Check that there is pressure in sample supply line.
	There is an obstruction upstream of the FLM.	Check that sample fluid is passing through the probe and isolation valves.
	There is no process pressure.	Check that the process line is pressurized.
Pressure indicator (PI) shows low pressure.	Configuration 3 and 4, the plug valve (PV) may be open.	Close the plug valve (PV).
	The needle valve (NV1) is fully open.	Turn the needle valve handle clockwise to restrict flow and increase pressure.
	The relief valve (RV) is relieving pressure and flowing to the vent.	Check the set pressure on the relief valve and increase if necessary.
	Pressure indicator (PI) is damaged.	Check the pressure indicator (PI) and replace if necessary.
	There is low process pressure.	Check the pressure in the process pipe near the sampling nozzle.
	If flow rate is acceptable, there may be a partial blockage in probe or sample transport lines to the FLM.	Partially close the needle valve (NV1) and check for pressure increase on the pressure indicator (PI) – if pressure increases there may be an upstream flow restriction.
	There is a flow restriction external to the FLM (ex. process probe or regulator not properly sized for the system).	Check the pressure at the probe or regulator outlet – if the system is losing pressure replace with a wider-bore probe or different regulator.
	During initial startup the flow is too low, the fast-loop supply line may be too narrow or too long.	Replace the fast-loop supply and return lines with larger tubing.
Pressure indicator (PI) shows high pressure.	There is high process pressure.	Reduce the pressure in the process pipe near the sampling nozzle.
	The needle valve (NV1) is restricting flow.	Turn the needle valve handle counter clockwise to increase flow and release pressure.
	Pressure indicator (PI) is damaged.	Check the pressure indicator (PI) and replace if necessary.
	If using a liquid fast-loop pump, the return line or process isolation valve may be blocked.	Check that the process isolation valve and all valves in the return line are fully open. Then check for possible blockage.

Only available through authorized
Swagelok sales and service representatives.

Troubleshooting

Symptom	Cause	Remedy	
The loop pressure is acceptable but there is little or no flow.	The needle valve (NV1) is closed too much.	Turn needle valve counter clockwise to increase the flow.	
	Configuration 3 and 4, the plug valve (PV) may be open.	Close the plug valve (PV).	
	If zero flow indicated, the flowmeter pointer is not following float position.	1/4 in. FLM, close the metering valve and wait for one minute. Slowly open the metering valve and adjust flow to desired rate. 1/2 in. FLM, close the needle valve and wait for one minute. Slowly open the needle valve and adjust flow to desired rate.	
	The flowmeter float is stuck in the tube.		Adjust the flow rate with the needle valve (NV1) and observe whether the flowmeter indicates the changes.
			Flush the system with solvent to remove oil and solid deposits.
			Remove the flowmeter and clean the inside of the flow tube.
			Replace the flowmeter.
	One of the bypass valves is not fully closed.		Move the black handle to the right and verify the two ball valves (BV1/BV2) are fully closed.
			Release set screws, reposition handle, and retighten set screws.
	Fast-loop pump (if used) is damaged.		Check the rotation speed of the fast-loop pump.
Check the flow rate from pump – repair or replace pump, as necessary.			
The fast-loop return line or process return nozzle is partially or fully blocked.		Check that all valves in fast loop system external to FLM are fully open.	
The process return pressure is too high.		Find a lower pressure point for return to process.	
During initial startup the flow is too low, the fast-loop supply line may be too small or too long.		Replace the fast-loop supply and return lines with larger tubing.	

Only available through authorized Swagelok sales and service representatives.

Troubleshooting

Symptom	Cause	Remedy
Fast-loop pressure and flow are acceptable, but there is little or no flow to the analyzer.	The filter element is obstructed.	Replace the filter element.
	Filter element is becoming frequently obstructed (e.g. daily replacement needed).	If possible, increase the fast-loop flow and check for improvement.
		If the additional time delay is acceptable, decrease the filtered sample flow (consider reducing analyzer bypass flow).
		Change the element to one with a larger pore size – if analyzer can accept the additional particle load.
	If the analyzed sample returns to the FLM, there may not be enough pressure drop in the FLM to drive the sample flow through the analyzer.	Restrict the fast-loop flow to increase sample pressure by turning needle valve (NV1) handle clockwise – being careful not to reduce flow too much.
		Check that the sample return valve (BV3) is fully open – release set screws, reposition handle, and retighten set screws if necessary
		Consider changing the method of disposing of the analyzed sample.
	The check valve (CV1) is not cracking.	Maintain or replace the check valve.
Pressure at sample return point is too high.	If the sample is returned via fast-loop return to process, reduce the return line pressure drop by installing a larger size tube or pipe for sample return line to process.	
	Consider changing the method of disposing of the analyzed sample.	
There is high flow resistance in the sample path to the analyzer external to the FLM.		Check all sample conditioning equipment, analyzer flow path, and analyzer vent for a closed valve or obstruction.
There is no flow in the grab sample outlet.	The needle valve (NV2) is closed.	Open the needle valve by turning the handle counter clockwise.
	Pressure indicator (PI) shows zero or low pressure.	See cause and remedy for Pressure indicator (PI) shows no or low pressure.
There is no purge flow.	The needle valve (NV3) is closed.	Open the needle valve by turning the handle counter clockwise.
	There is insufficient purge fluid pressure.	Check that the purge fluid is supplied to the FLM at a sufficient pressure.
	Drain valve is not open	Configuration 4, open the plug valve (PV).
	The drain is blocked.	Check that there is no closed valve in the drain line external to the FLM.
Remove any blockage from the drain.		
The process sample is leaking into system during purge.	The FLM is not fully in bypass.	Move the black handle to the left.
	One of the ball valves (BV1/BV2) is not fully in bypass.	Release set screws, reposition handle, and retighten set screws.
	Ball valves BV1 or BV2 need packing adjusted.	Tighten the packing according to Maintenance , page 16.

Only available through authorized Swagelok sales and service representatives.

Troubleshooting

Symptom	Cause	Remedy
The relief valve is open.	There is excess process pressure.	See cause and remedy for Pressure indicator (PI) shows high pressure.
	The set pressure is too low.	Increase the set pressure if necessary.
		Replace valve spring with the next higher range.
There is backflow into the analyzer.	Check valve (CV1) is stuck open.	Maintain or replace the check valve. Verify orientation when the check valve is reinstalled.
Pressure indicator (PI) pointer is vibrating excessively.	Fast loop pressure is pulsating.	Consider replacing PI with a liquid-filled gauge
	The snubber is incorrect for the sample viscosity.	Replace the snubber with a more restrictive SUS range.

Only available through authorized
Swagelok sales and service representatives.

Swagelok Tube Fitting Instructions for 1 in. (25 mm) and smaller fittings

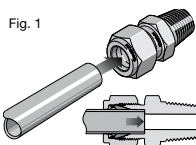

Fig. 1

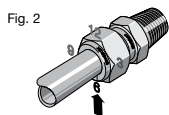

Fig. 2

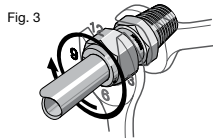

Fig. 3

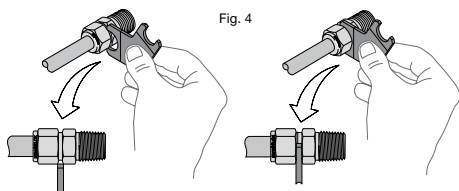

Fig. 4

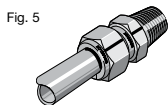

Fig. 5

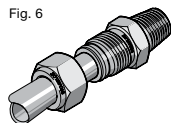

Fig. 6

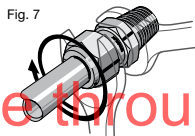

Fig. 7

Installation

These instructions apply to both traditional fittings and to fittings with the advanced back-ferrule geometry.

1. Fully insert the tube into the fitting and against the shoulder; rotate the nut finger-tight. *Fig. 1.*

High-Pressure Applications and High Safety-Factor Systems: Further tighten the nut until the tube will not turn by hand or move axially in the fitting.

2. Mark the nut at the 6 o'clock position. *Fig. 2.*
3. While holding the fitting body steady, tighten the nut one and one-quarter turns to the 9 o'clock position. *Fig. 3.*

Note: For 1/16, 1/8, and 3/16 in.; 2, 3, and 4 mm tube fittings, tighten the nut three-quarters turn to the 3 o'clock position.

Gaugeability

On initial installation, the Swagelok gap inspection gauge assures the installer or inspector that a fitting has been sufficiently tightened.

Position the Swagelok gap inspection gauge next to the gap between the nut and body. *Fig. 4.*

- If the gauge will not enter the gap, the fitting is sufficiently tightened.
- If the gauge will enter the gap, additional tightening is required.

Reassembly Instructions — You may disassemble and reassemble Swagelok tube fittings many times.

Warning

Always depressurize the system before disassembling a Swagelok tube fitting.

1. Prior to disassembly, mark the tube at the back of the nut; mark a line along the nut and fitting body flats. *Fig. 5.*

Use these marks to ensure you return the nut to the previously pulled-up position.

2. Insert the tube with preswaged ferrules into the fitting body until the front ferrule seats against the fitting body. *Fig. 6.*
3. While holding the fitting body steady, rotate the nut with a wrench to the previously pulled-up position as indicated by the marks on the tube and the flats; at this point you will feel a significant increase in resistance. *Fig. 7.*
4. Tighten the nut slightly.

Caution

Do not use the gap inspection gauge with reassembled fittings.

Caution

Do not mix or interchange parts with those of other manufacturers.

Only available through authorized Swagelok sales and service representatives.

For additional information, see the *Gaugeable Tube Fittings and Adapter Fittings* catalog, MS-01-140.

Swagelok® VCO® Fittings Installation Instructions

Bodies without weld fittings

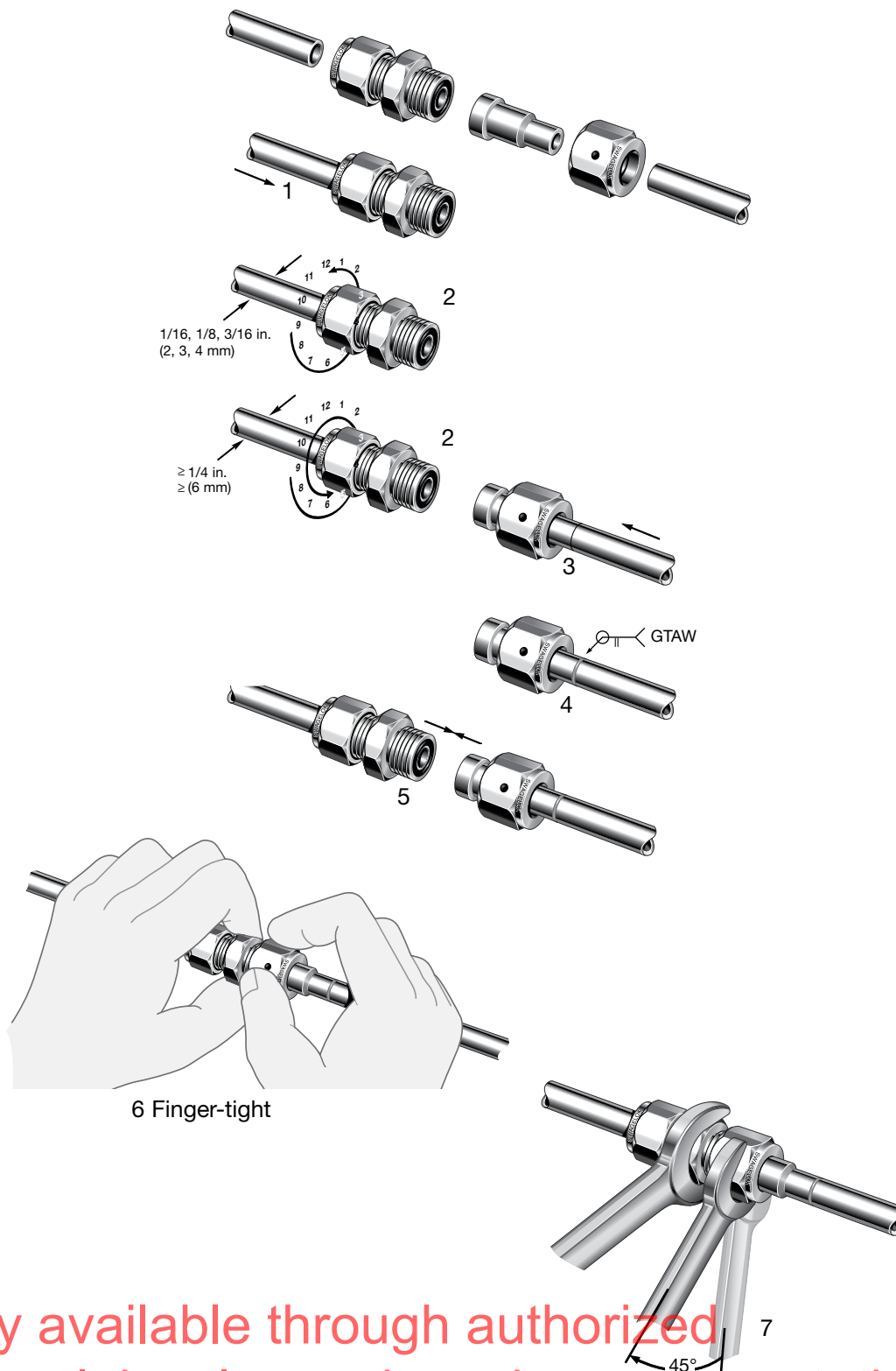

Only available through authorized Swagelok sales and service representatives.

Swagelok® VCO® Fittings Installation Instructions

Bodies with weld fittings

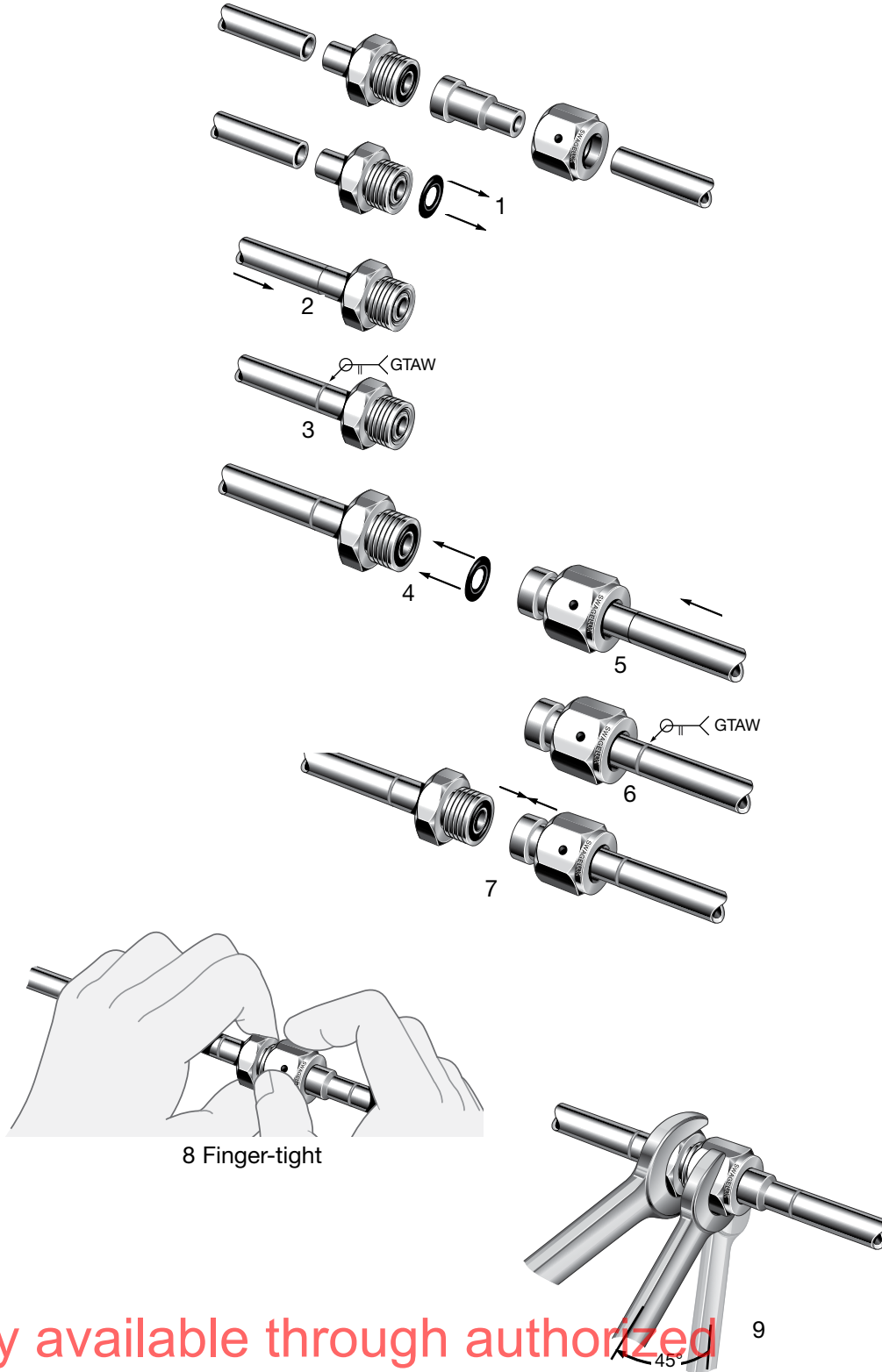

Only available through authorized Swagelok sales and service representatives.

40 Series Valve Packing Adjustment

IMPORTANT

This valve is adjusted for factory testing with nitrogen at 1000 psig (69 bar) or the rated pressure if lower than 1000 psig (69 bar). Packing must be readjusted for service at higher than test pressure. **⚠ Warning: Packing adjustment may be required during the service life of the valve to prevent leakage.** Before servicing any installed valve you must depressurize the system, cycle the valve, and purge the valve. Adjust the packing by turning the packing bolt clockwise in 1/16-turn increments until leak-tight performance is achieved. Always verify proper operation upon installation.

Only available through authorized
Swagelok sales and service representatives.

40G Series Valve Packing Adjustment

IMPORTANT

This valve is factory tested with nitrogen at 1000 psig (69 bar), or the rated pressure if lower than 1000 psig (69 bar).

Periodic maintenance: Packing adjustments may be required during the service life of the valve to prevent leakage.

Adjusting the Packing

1. Adjust the packing by turning the packing bolt clockwise in 1/16-turn increments until leak-tight performance is achieved.
2. Test valve for proper function and operation.

⚠ Before removing any installed valve from the system, you must

- depressurize the system
- cycle the valve
- purge the valve

Only available through authorized
Swagelok sales and service representatives.

R3A Series Externally Adjustable Relief Valves Maintenance Instructions

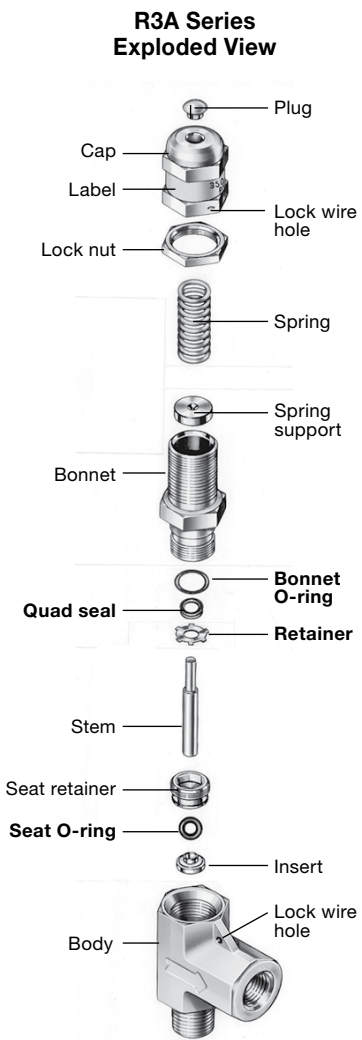

Spring Kit

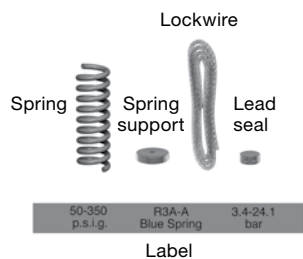

Tools Required

Tool	Size	Part
Open-end wrench	3/4 in. Thin head (3/16 in. max)	Lock nut
	3/4 in.	Cap
Crow's foot	3/4 in. Thin head (3/16 in. max)	Lock nut
Hex bit socket	5/64 in.	Handle set screw
Torque wrench, capable of:	10 in.-lb (1.1 N-m)	Set screw
	100 in.-lb (11.3 N-m)	Lock nut
Pic	n/a	O-rings

Spring Kit Identification

Spring Designator and Color	Set Pressure Range psig (bar)	Initial Cap Position (number of turns)
Spring Kit Basic Ordering Number: 177-R3A-K1-		
A	Blue 50 to 350 (3.4 to 24.1)	9
B	Yellow 350 to 750 (24.1 to 51.7)	8.5
C	Purple 750 to 1500 (51.7 to 103)	9
D	Orange 1500 to 2250 (103 to 155)	6
E	Brown 2250 to 3000 (155 to 206)	6
F	White 3000 to 4000 (206 to 275)	6
G	Red 4000 to 5000 (275 to 344)	6
H	Green 5000 to 6000 (344 to 413)	6

Only available through authorized Swagelok sales and service representatives.

R3A Series Externally Adjustable Relief Valves Maintenance Instructions

- ⚠ WARNING**
Before servicing any installed valve, you must
- depressurize system
 - cycle valve
 - purge the valve
- ⚠ WARNING**
Residual material may be left in the valve and system.
- ⚠ CAUTION**
Do not scratch any sealing surfaces while following these instructions. Valve performance could be affected.

Spring Installation

1.

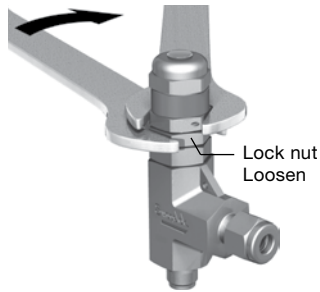

2.

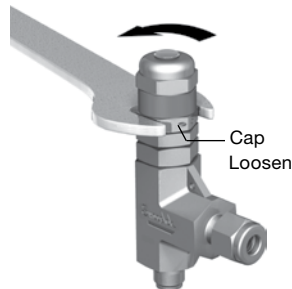

3.

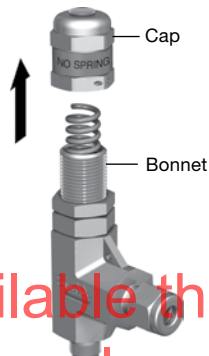

Definition of Symbols

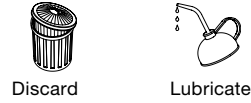

4.

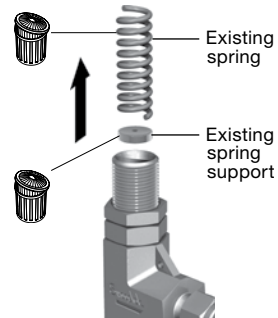

5. Make sure all components are clean.

6.

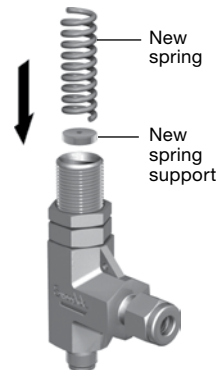

7.



8.

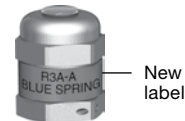

9.

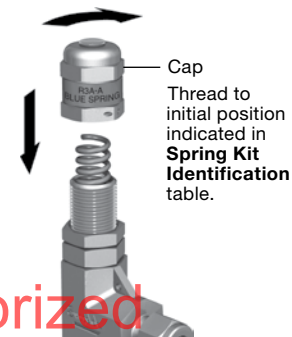

Only available through authorized Swagelok sales and service representatives.

R3A Series Externally Adjustable Relief Valves Maintenance Instructions

10.

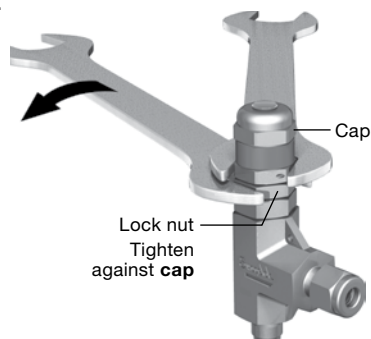

11. Test for set pressure.

12. To adjust set pressure, relieve system pressure and loosen **lock nut**.

- To increase set pressure, tighten **cap** as needed.
- To decrease set pressure, loosen **cap** as needed.

13. Repeat steps 10 through 12 as necessary to obtain desired set pressure.

14.

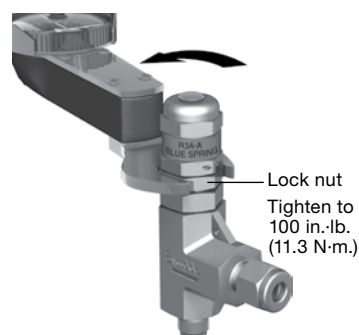

15.

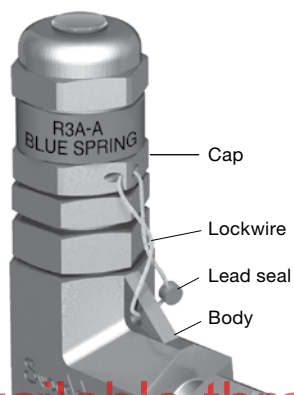

Manual Override Conversion

Manual Override Kit



1. Follow steps 1 through 4 in the Spring Installation section. Springs A, B, or C can be reused in step 3.

2.

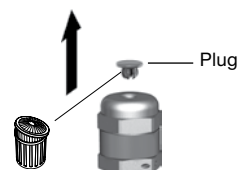

3.

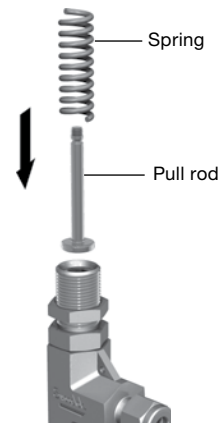

4.

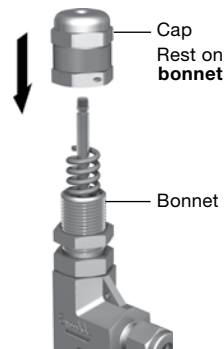

Only available through authorized Swagelok sales and service representatives.

R3A Series Externally Adjustable Relief Valves Maintenance Instructions

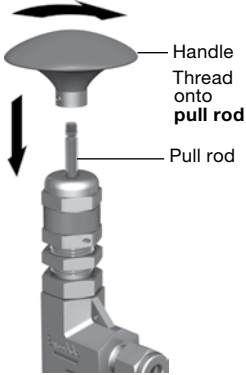
5. 

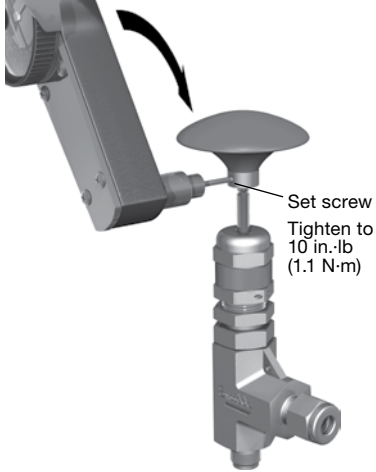
Handle
Thread onto
pull rod
Pull rod
6. 

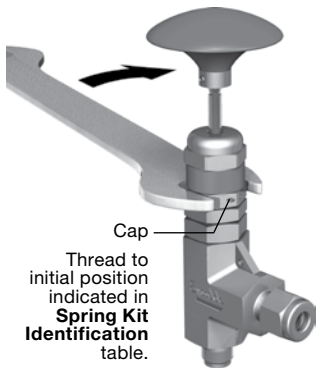
Set screw
Tighten to
10 in.-lb
(1.1 N-m)
7. 







Cap
Thread to
initial position
indicated in
**Spring Kit
Identification**
table.
8. To adjust set pressure, see steps 10 through 13 in the **Spring Installation** section.

Only available through authorized
Swagelok sales and service representatives.

R3A Series Externally Adjustable Relief Valves Maintenance Instructions

Seat Replacement

Tools Required

Tool	Size	Part
		
Open-end wrench	3/4 in. Thin head (3/16 in. max)	Lock nut
	3/4 in.	Cap, Bonnet nut
	7/8 in.	Body wrench pad
		
Crow's foot	3/4 in.	Bonnet nut
		
Hex wrench	5/16 in.	Seat retainer
		
Hex bit socket	5/16 in.	Seat retainer
		
Torque wrench, capable of:	250 in.-lb (28.2 N-m)	Seat retainer
	600 in.-lb (67.8 N-m)	Bonnet nut
		
Pic	n/a	O-rings

Seal Kit

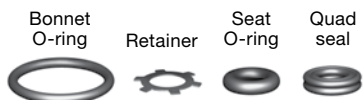

WARNING
 Before removing any installed valve, you must

- depressurize system
- cycle valve
- purge valve

WARNING
 Residual material may be left in the valve and system.

CAUTION
 Do not scratch any sealing surfaces while following these instructions. Valve performance could be affected.

Definition of Symbols



Discard



Lubricate
 With system compatible lubricant

1. Remove valve from system.

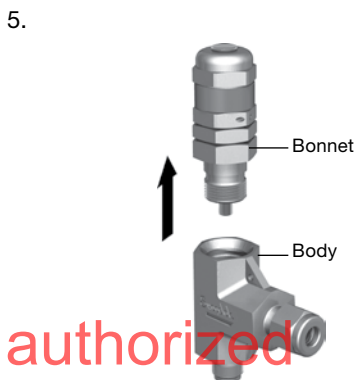
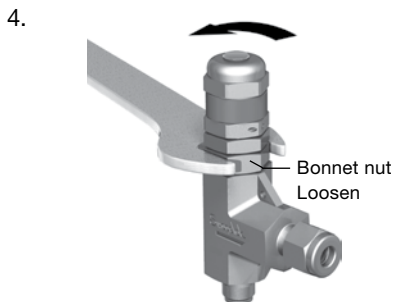
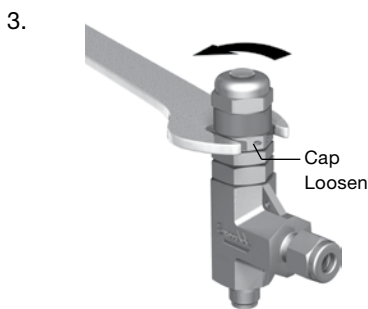
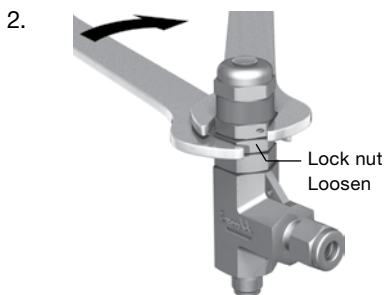

Only available through authorized Swagelok sales and service representatives.

R3A Series Externally Adjustable Relief Valves Maintenance Instructions

6.

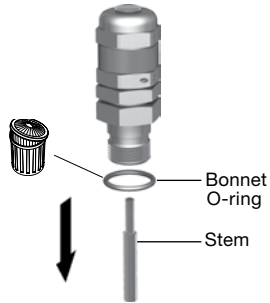

7.

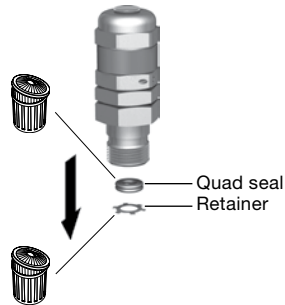

8.

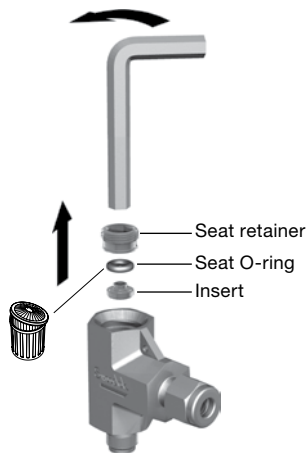

9. Make sure all components are clean.

10.

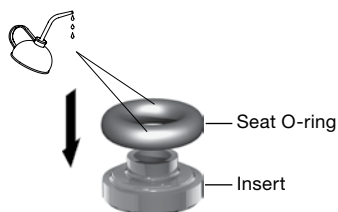

11.

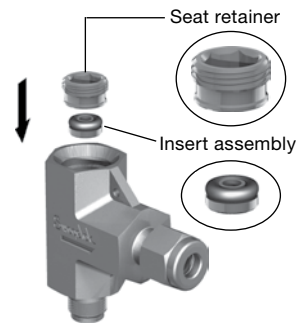

12.

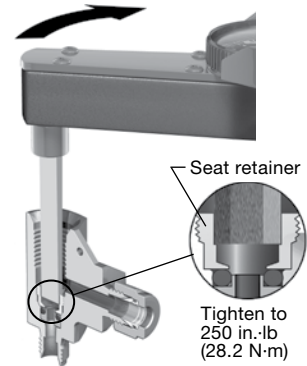

13.

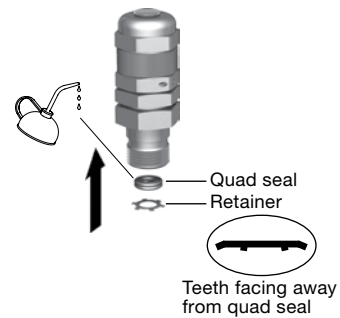

14.

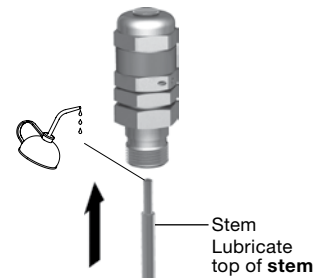

Only available through authorized Swagelok sales and service representatives.

R3A Series Externally Adjustable Relief Valves Maintenance Instructions

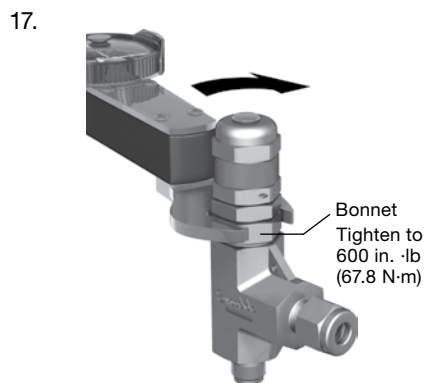
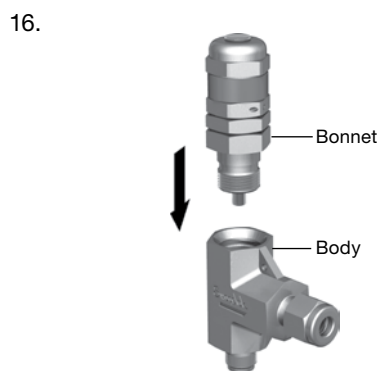
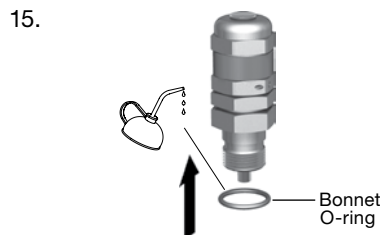

18. To adjust set pressure, see steps 10 through 13 in the **Spring Installation** section.

19. Install valve in system. Grip valve on wrench pad during installation.



R3A Series Cutaway

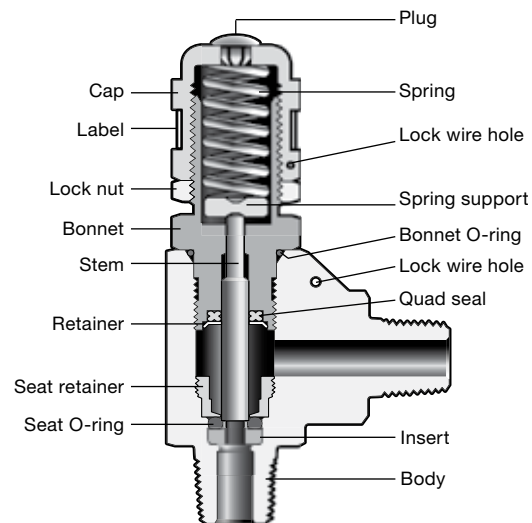

⚠ Swagelok proportional relief valves should never be used as code safety relief valves.

⚠ Some system applications require relief valves to meet specific safety codes. The system designer and user must determine when such codes apply and whether these relief valves conform to them.

⚠ Swagelok proportional relief valves are not "Safety Accessories" as defined in the Pressure Equipment Directive 97/23/EC:

Only available through authorized Swagelok sales and service representatives.

R4 Series Relief Valve Maintenance Instructions

Seal and Stem Replacement Instructions

Contents:

- 1 quad seal
- 1 O-ring
- 1 bonded stem

Quad Seal and O-Ring Replacement

1. Remove valve from system.
2. Loosen cap to relieve spring pressure.
3. Remove bonnet from body.
4. Remove stem and retainer from bonnet.
5. Remove quad seal from bonnet.
6. Make sure all parts are clean before reassembly.
7. Install new quad seal into bonnet. (Lubricate with system compatible lubricant.)
8. Place retainer in bonnet, then insert stem into bonnet through retainer and quad seal.
9. Remove and replace bonnet O-ring. (Lubricate with system compatible lubricant.)
10. Thread bonnet into body and torque to 400 in.-lb. (45 N·m).
11. Adjust desired set pressure as described in steps 7 through 10 in the Spring Installation section on reverse side.
12. Install valve in system. Grip valve on wrench pad during installation.

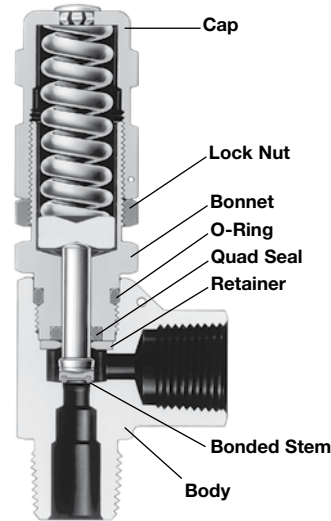

Stem and O-Ring Replacement

1. Remove valve from system.
2. Loosen cap to relieve spring pressure.
3. Remove bonnet from body.
4. Remove stem from bonnet.
5. Make sure all parts are clean before reassembly.
6. Place new stem into bonnet.
7. Remove and replace bonnet O-ring. (Lubricate with system compatible lubricant.)
8. Thread bonnet into body and torque to 400 in.-lb. (45 N·m).
9. Adjust desired set pressure as described in steps 7 through 10 in the Spring Installation section on reverse side.
10. Install valve in system. Grip valve on wrench pad during installation.

Spring Kit Identification

Spring Kit Ordering Number	Color Code	Nominal Cracking Pressure psig (bar)	Initial Cap Position, number of turns
177-13K-R4-A	Blue	50 to 350 (3.4 to 24.1)	12.5
177-13K-R4-B	Yellow	350 to 750 (24.1 to 51.7)	13.5
177-13K-R4-C	Purple	750 to 1500 (51.7 to 103)	13.5

Only available through authorized Swagelok sales and service representatives.

R4 Series Relief Valve Maintenance Instructions

Spring Installation

⚠ Warning: Relieve system pressure before installing spring.

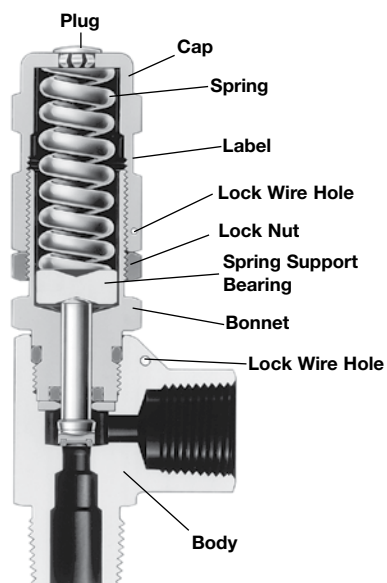

1. Loosen lock nut and remove the cap from bonnet.
2. Remove existing spring if necessary.
3. Make sure all components are clean.
4. Place spring support bearing in valve with bearing side UP.
5. Install proper spring for desired set pressure range.
6. Replace existing label with new label. Check this label against spring identification table for proper set pressure range.
7. Thread cap onto bonnet to initial position indicated in Spring Kit Identification Table. Tighten lock nut against cap and test for set pressure.
8. Relieve system pressure, unthread cap as needed, and retest. Repeat procedure as necessary to obtain desired set pressure.
9. Tighten lock nut against the cap to 100 in.-lb. (11 N·m).

10. Lock wire the cap and body together to maintain relief setting.

Manual Override Conversion

⚠ Warning: Relieve system pressure before installing manual override handle.

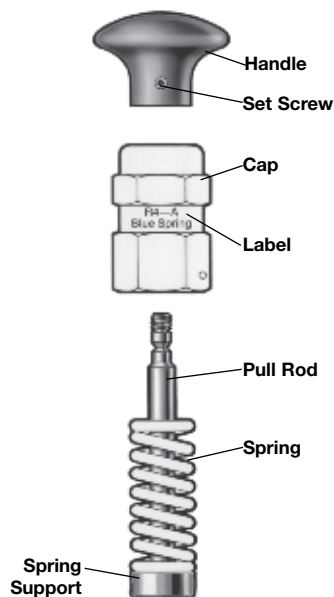

1. Loosen lock nut and remove the cap from bonnet.
2. Remove the plug from the cap.
3. Remove existing spring and spring support bearing.
4. Place new bearing and thrust washers over pull rod, resting them on the spring support.
5. Install pull rod into bonnet.
6. Place blue "A" spring over pull rod, resting it on the thrust washer.
7. Place the cap over pull rod, resting it on bonnet.
8. Thread handle onto pull rod. Tighten set screw on handle to 20 in.-lb. (2.2 N·m) with a 5/64 in. hex wrench.
9. Engage the cap threads.

To adjust the set pressure, refer to steps 7 through 10 in the "Spring Installation" section.

Only available through authorized Swagelok sales and service representatives.

Plug Valve Subassembly Replacement and O-Ring Rebuild Instructions

It is recommended that a replacement kit be used rather than a rebuild kit. Insufficient lubrication, twisting of seals, etc., can adversely affect performance.

Kit Contents

Replacement Kit:	O-ring Kit:
· Handle	O-rings (3 total, 2 sizes)
· Roll pin	
· Plug	
· O-rings (3)	
· Snap ring	

Note: Brass plugs have green PTFE coating, 316 SS plugs have gray PTFE coating.

Procedure

⚠ **Before servicing any installed valve, you must:**

- depressurize system
- cycle valve
- purge the valve.

Replacement Kit Instructions

1. Remove snap ring using snap ring pliers or similar tool, and discard. See Fig 4. Turn handle to the open position.
2. Lift up handle to remove old plug and discard entire subassembly.
3. Clean body bore and lubricate lightly with a silicone-based lubricant.
4. Remove protective sleeve from new plug. Insert plug straight down into body. See Fig 3.

Note: Do not pinch O-rings between body and plug.

5. Install snap ring with snap ring pliers or similar tool. See Fig 4.
6. Test the valve for proper operation.

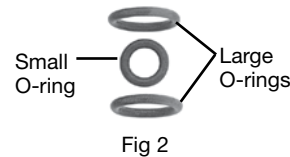
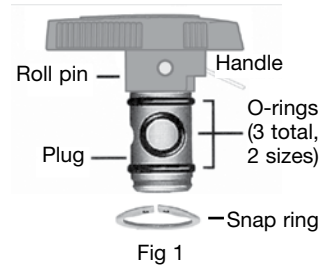

O-Ring Kit Instructions

1. Remove snap ring using snap ring pliers or similar tool. See Fig 4. Set aside. Turn handle to the open position.
2. Lift up handle to remove plug, remove the O-rings from the plug, and discard O-rings. See Fig 3.
3. Clean body bore and lubricate lightly with a silicone-based lubricant. Also lubricate entire surface of new O-rings with a silicone-based lubricant. Install O-rings on plug, with the larger two around the top and bottom of the plug, the smaller one on the side.
4. Insert plug straight down into body. See Fig 3.

Note: Do not pinch O-rings between body and plug.

5. Install snap ring with snap ring pliers or similar tool. See Fig 4.
6. Test the valve for proper operation.



Only available through authorized Swagelok sales and service representatives.

Repacking Instructions for N and HN Series Valves

Kit Contents:

PTFE Packing	UHMWPE Packing
Packing (1)	Packing (1)
Packing support (2)	Lubricant (1)
Lubricant (1)	Instruction sheet (1)
Instruction sheet (1)	MSDS (1)
MSDS (1)	

Grafoil® Packing	PEEK Packing
Packing ¹	Packing (2)
Lubricant (1)	Packing support (2)
Instruction sheet (1)	Lubricant (2)
MSDS (1)	Instruction sheet (1)
	MSDS (2)

¹Number of packings will vary according to valve series.

⚠ WARNING BEFORE SERVICING ANY INSTALLED VALVE, YOU MUST:

- depressurize system
- cycle the valve
- purge the valve.

Disassembly:

1. Loosen the lock nut and packing bolt.
2. Remove the bonnet assembly from the valve body. Do not remove the union nut from the bonnet.
3. Turn the stem into the bonnet until the handle slightly touches the packing bolt.
4. Loosen set screw and remove handle.
5. Remove packing bolt and lock nut.
6. Remove the stem from the bonnet. Turn the bonnet upside down to remove the packing(s), packing supports (in PTFE and PEEK packed valves), and the gland.

NOTE: Be very careful when removing packing so as not to damage the inside of the bonnet.

7. Discard the packing(s) and packing supports (in PTFE and PEEK packed valves). **DO NOT** discard the gland.
8. Clean all reusable parts thoroughly in solvent and dry all parts.

Reassembly:

9a. PTFE Packing: Lubricate the stem threads with MS-LT-NNS-1 and re-insert the stem through the bottom of the bonnet. Lubricate the valve body threads and the body to bonnet sealing area with MS-LT-NNS-1 and place the bonnet assembly onto the body. Tighten the union nut onto the body finger-tight. Place one of the packing supports into the bonnet. Place the packing into the bonnet by carefully pushing down with a blunt instrument. Be careful not to damage any stem or bonnet threads. Put the second packing support into the bonnet on top of the packing. Place the gland into the bonnet. Proceed to step 10.

9b. UHMWPE Packing: Lubricate the stem threads with MS-LT-NNS-1 and re-insert the stem through the bottom of the bonnet. Lubricate the valve body threads and the body to bonnet sealing area with MS-LT-NNS-1 and place the bonnet assembly onto the body. Tighten the union nut onto the body finger-tight. Place the packing into the bonnet with a blunt instrument. Be careful not to damage any threads. Place the gland into the bonnet. Proceed to step 10.

9c. Grafoil Packing: Lubricate the stem threads, stem shank, and each individual piece of grafoil packing with MS-LT-NNS-1. Re-insert the stem through the bottom of the bonnet. Lubricate the valve body threads and the body to bonnet sealing area with MS-LT-NNS-1 and place the bonnet assembly onto the valve body. Tighten the union nut onto the body finger-tight. Push each packing into the bonnet one at a time, using the gland. **Use all of**

Only available through authorized Swagelok sales and service representatives.

Repacking Instructions for N and HN Series Valves

the packings included in the kit. Be careful not to damage any threads. Place the gland into the bonnet. Proceed to step 10.

9d. PEEK Packing: Lubricate the stem threads, stem shank, and the packings with MS-LT-WL7. Re-insert the stem through the bonnet. Lubricate the valve body threads and the body to bonnet sealing area with MS-LT-NNS and place the bonnet assembly onto the body. Tighten the union nut onto the body finger-tight. Place one packing support inside the bonnet and press it down with a blunt instrument. Be careful not to damage any stem or bonnet threads. Insert the lubricated bottom packing and then the top packing. Press down into the bonnet. Insert the second packing support, press down. Insert the gland and press down into the bonnet. Proceed to step 10.

All Assemblies:

- Lubricate the outer threads on the packing bolt and screw into the bonnet.
- Lubricate the top (2) or (3) threads on the bonnet and screw lock nut onto the bonnet.
- Place the handle on the stem. Be certain that the set screw hole is aligned with the indentation in the stem before tightening the set screw.
- Back stem out of the bonnet (2) or (3) turns, to prevent galling during the torquing procedure.
- Torque union nut to body according to torque chart.
- Tighten packing bolt to seal packing against given system pressures.
- Hold packing bolt in place and tighten the lock nut against the packing bolt.

Torque Chart

Valve Series	Torque, in.·lb (N·m)
3N	360 (40.6)
3HN, 6N	780 (88.1)
6HN	1080 (122)
12N	2200 (246)

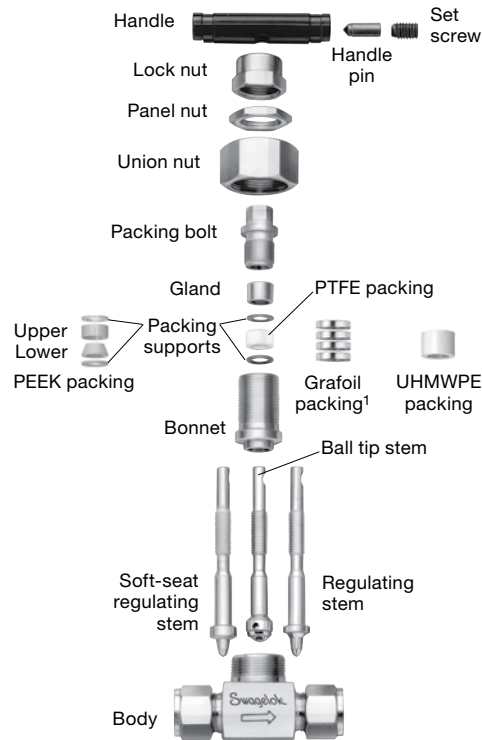

¹ Number of packings will vary according to valve series.

Only available through authorized Swagelok sales and service representatives.

Service Instructions CH Series Check Valve

Contents

- Component Identification
- Tool Requirements
- Installation
- Testing
- Kit Contents
- Maintenance
- Troubleshooting

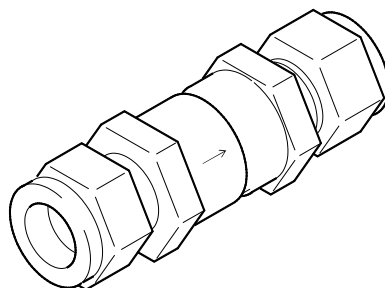

The valve in this procedure is shown with Swagelok® Tube Fitting end connections. These instructions also apply to check valves with pipe ends and check valves with VCR® and VCO® ends.

Component Identification

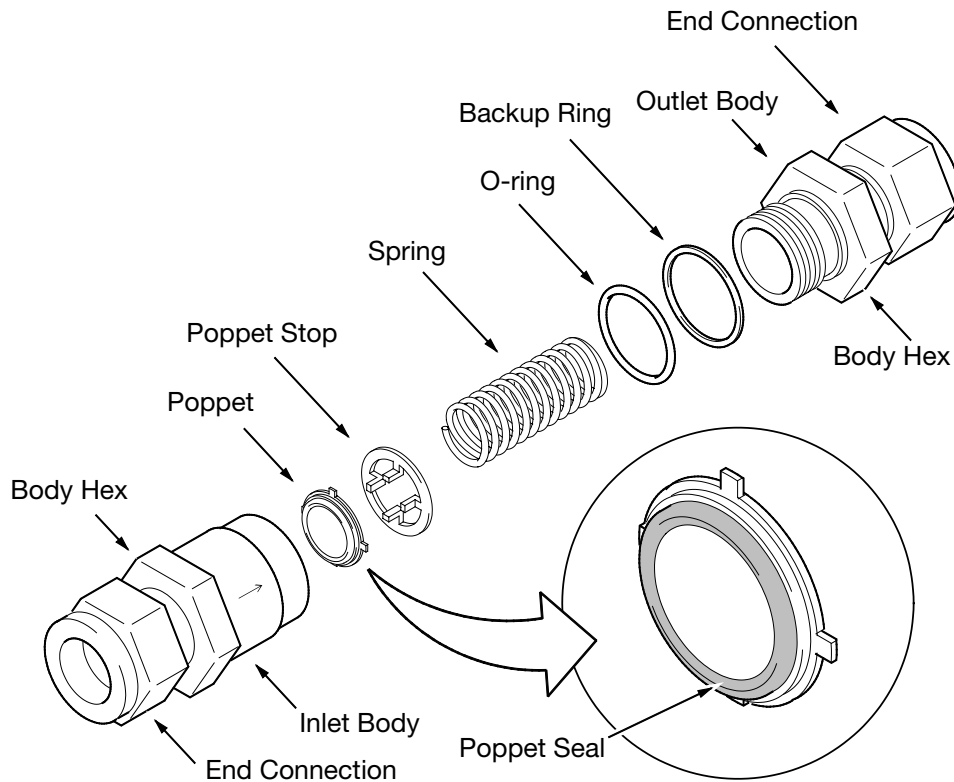

**Only available through authorized
Swagelok sales and service representatives.**

Service Instructions CH Series Check Valve

Tool Requirements

Tool size depends on the nominal end connection size and style. See the chart below.

Nominal End Connection Size	Tool Size and Quantity		
	Wrenches		Socket
	for body Hex Qty. (2)	for End Connection Qty. (1)	for body Hex Qty. (1)
1/8 in.	11/16 in.	7/16 in.	11/16 in.
1/4 in.	11/16 in.	9/16 in.	11/16 in.
6 mm	11/16 in.	14 mm	11/16 in.
3/8 in.	1 in.	11/16 in.	1 in.
1/2 in.	1 in.	7/8 in.	1 in.
1/2 in. FNPT	1 1/16 in.	1 1/16 in.	1 1/16 in.
1/2 in. BSP/ISO	1 1/16 in.	1 1/16 in.	1 1/16 in.
8 mm	1 in.	16 mm	1 in.
10 mm	1 in.	19 mm	1 in.
12 mm	1 in.	22 mm	1 in.
3/4 in.	1 5/8 in.	1 1/8 in.	1 5/8 in.
1 in.	1 5/8 in.	1 1/2 in.	1 5/8 in.
22 mm	1 5/8 in.	1 1/2 in.	1 5/8 in.
25 mm	1 5/8 in.	40 mm	1 5/8 in.

Torque wrench to read 200 in. · lb (22 N · m).

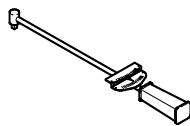

Spring Kit Contents

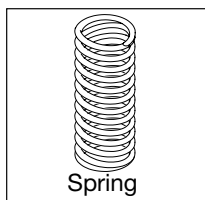

Seal Kit Contents



Installation

1. Refer to the flow direction arrow on the check valve and install the valve in the correct orientation.

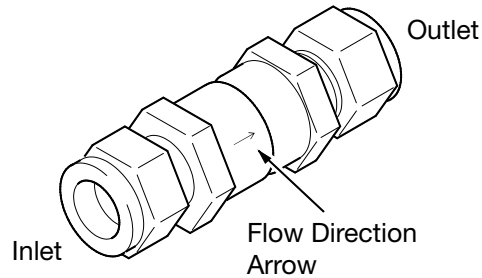

2. Follow the fitting assembly instructions for Swagelok, VCR, and VCO fittings.
3. When installing a valve with pipe fittings or straight thread fittings, follow standard industry practices.

Testing

1. Test the valve to ensure there is no leakage to the atmosphere.
2. Check for correct cracking pressure.
3. Test the valve to ensure it stops reverse flow.

Maintenance

Disassembly

1. Remove the check valve from the system.
2. Separate the inlet body from the outlet body.

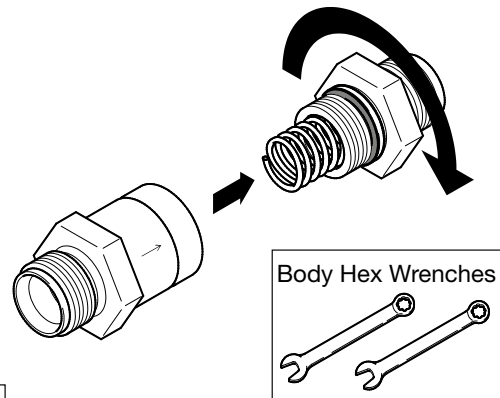

Only available through authorized Swagelok sales and service representatives.

Service Instructions CH Series Check Valve

Outlet Body

3. Remove the spring.

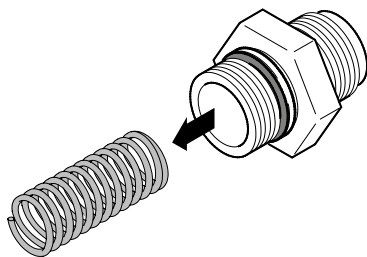

4. Remove the O-ring.

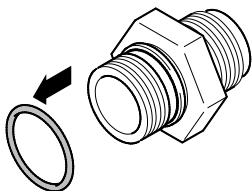

5. Remove the backup ring.

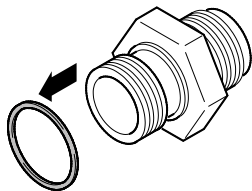

Inlet Body

6. Remove the poppet stop.

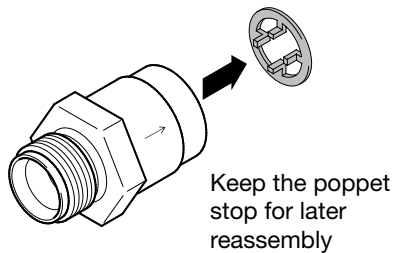

7. Remove the poppet.

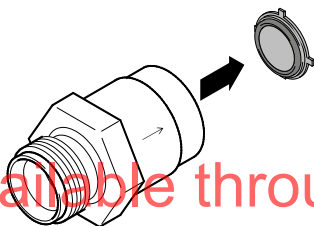

Reassembly

Outlet Body

1. Place the backup ring on the outlet body.

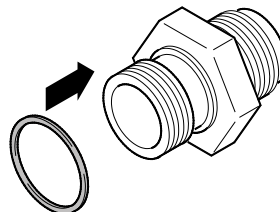

2. Lubricate the O-ring with a compatible lubricant.
3. Slide the O-ring over the threads against the backup ring.

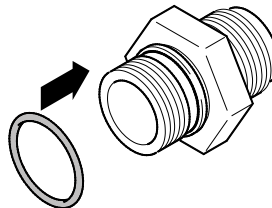

4. Insert the spring into the body.

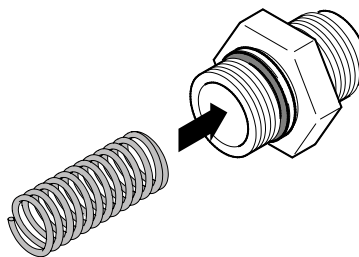

5. Lubricate the body threads with a system-compatible lubricant.

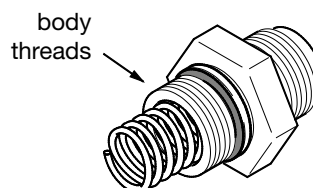

Only available through authorized
Swagelok sales and service representatives.

Service Instructions CH Series Check Valve

Inlet Body

6. Insert the poppet, bonded side first, into the body.

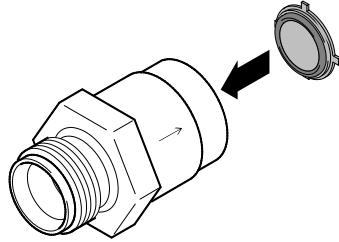

7. Insert the poppet stop, prongs first, into the body.

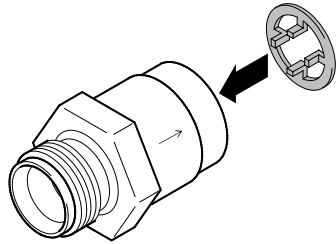

8. Thread the outlet and inlet bodies together.

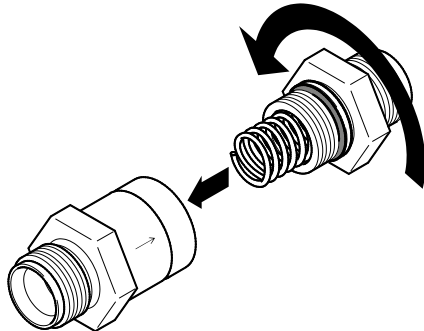

⚠ Note:

Do not pinch the O-ring and backup ring between the outlet and inlet bodies during assembly
The O-ring must fit tightly into the inlet body.

9. Look into the valve outlet port to verify that the spring is aligned in the center of the poppet stop.

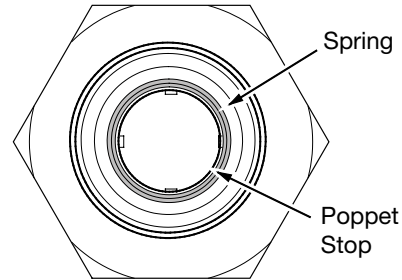

10. Tighten the valve bodies.

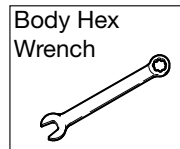
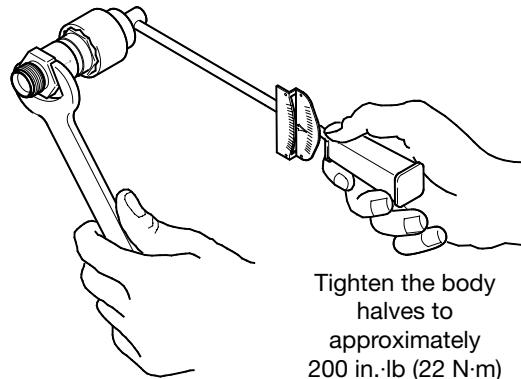

11. Refer to the Installation and Testing sections.

Only available through authorized
Swagelok sales and service representatives.

Service Instructions CH Series Check Valve

Troubleshooting

Symptom	Possible Causes	Reference to Pg 46	Corrective Action
Seal leakage	Poppet elastomer was chemically attacked	2	Replace poppet with a material that is compatible with the system fluid.
	Poppet elastomer was damaged	3	Replace poppet.
	Poppet contamination	1	Clean poppet and valve inside surfaces.
	Fluid deposits buildup on seat		Consider using two check valves in series.
	Upstream pressure is greater than the cracking pressure (when valve is not expected to be open)		Consider using a spring with a higher cracking pressure.
	Age or wear		Service during preventive maintenance. Clean and replace internal components as needed.
Reverse flow	Downstream pressure is less than the reseal pressure - when back pressure is required for sealing (lower cracking pressure springs) - and upstream pressure has dropped to 0.		Consider using a spring with a higher cracking pressure.
	Spring not centered on the poppet stop		Install spring per service instructions.
Leakage to the atmosphere	Incorrect reassembly of valve		Reassemble valve according to service instructions.
	Incorrect installation of valve	6	Use a backup wrench.
	End connection leakage		Inspet end connection for damage, replace if damaged.
			Reinstall the fitting to the valve end connection.
	Contamination on body O-ring	4	Clean O-ring and reassemble valve per service instructions.
Damaged O-ring	5	Replace O-ring. Reassemble valve according to service instructions.	
Helium leak test leakage	Check valve not compatible with helium leak test specifications	7	Consider using a positive shutoff valve.
Valve chatter or noise at operating pressures close to the cracking pressure	Cracking pressure of spring is too high.		Consider using a spring with a lower cracking pressure.
	Valve size exceeds system requirements		Consider using a smaller valve. Consider adding a flow restriction downstream of the valve.
Valve chatter or noise at high flow rates	Poppet and spring unstable in the flow stream		Consider using a spring with a higher or lower cracking pressure. Consider using a larger or smaller valve.
Fluid mixing	Check valve used to separate incompatible fluids		Consider using an appropriate positive shutoff valve. Check valves cannot isolate incompatible fluids.

Only available through authorized If the symptom persists, contact your independent Swagelok representative for assistance.

Swagelok sales and service representatives.

Service Instructions CH Series Check Valve

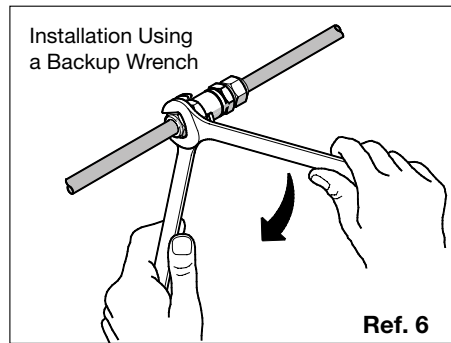
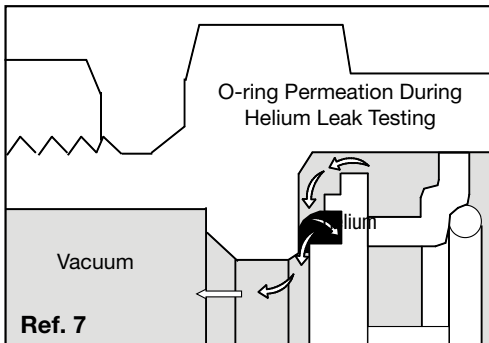
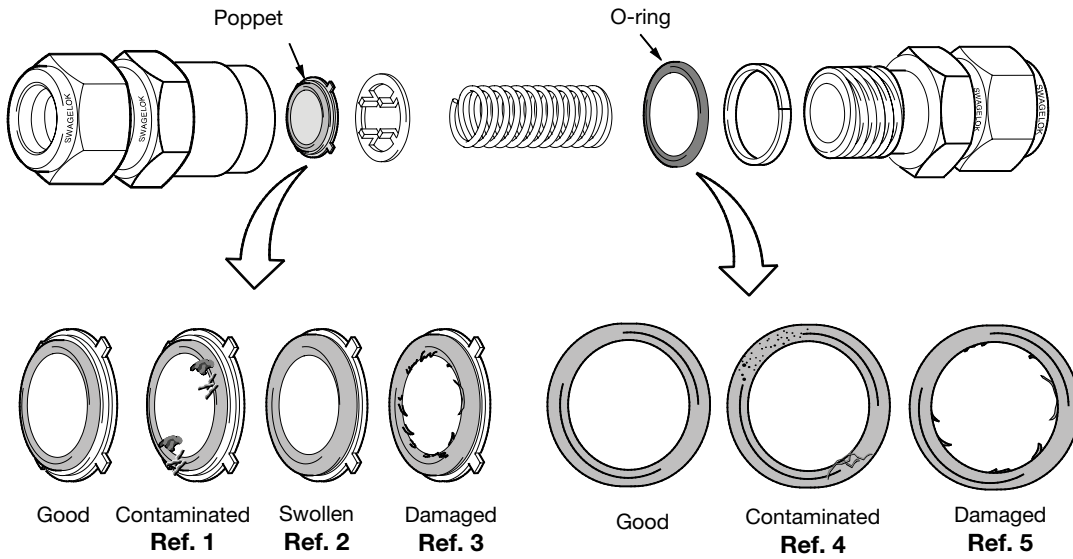

Safe Product Selection
When selecting a product, the total system design must be considered to ensure safe, trouble-free performance. Function, material compatibility, adequate ratings, proper installation, operation, and maintenance are the responsibilities of the system designer and user.

Only available through authorized Swagelok sales and service representatives.

Caution: Do not mix or interchange parts with those of other manufacturers.

Tornado Model 601 Element Replacement Kit Instructions Element Kit Part #601-5TX

**Tornado Model 601 Element
Replacement Kit Instructions**
Element Kit Part # 601-5TX

Teflon Element/Gasket Assemblies



41041 Black Bayou Rd, Gonzales, Louisiana, USA 70737
Phone (225) 644-5255 FAX (225) 644-3925
www.genefilters.com sales@genefilters.com

Rev. 04/02

Remove all sources of gas and liquid pressure from the Tornado.



Tools Required:
Inch-Pound Torque Wrench with 9/16" socket, Wrench



Use the wrench to remove the five 3/8" bolts and the Tornado cover.



Cover



Body



3/8" Bolts

Lay the cover down, element side-up.

Remove and discard the old element/gasket assembly.



New Element Assembly

Carefully remove a new element/gasket assembly from one of the clear plastic bags in the replacement kit for the Teflon elements. Hydrophobic and SS Screen elements are packaged and installed with a separate gasket. Grasp the assembly at its outer edge, taking great care not to bend or damage it.

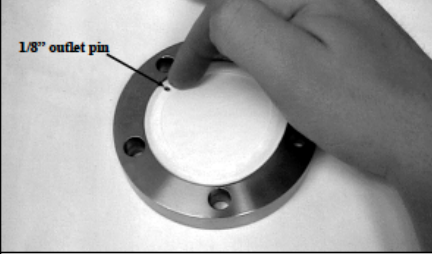

1/8" outlet pin

Carefully place the element/gasket assembly over the flow screen in the cover cavity with the 1/8" hole in the assembly over the 1/8" outlet pin. Press the outer edge of the assembly down so that it lays flat over the 1/8" pin into the cover cavity until it bottoms.

**Only available through authorized
Swagelok sales and service representatives.**

Tornado Model 601 Element Replacement Kit Instructions Element Kit Part #601-5TX

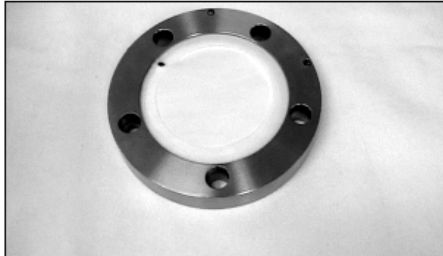

Do not press in the center of the assembly or element damage may occur. Carefully press the remaining outer edges of the assembly and "tuck" the assembly under the cover's ledge until it bottoms. The assembly should be flat and free of wrinkles or creases.

Align the cover with the assembly installed over the body and press the cover on the body to complete the assembly installation.

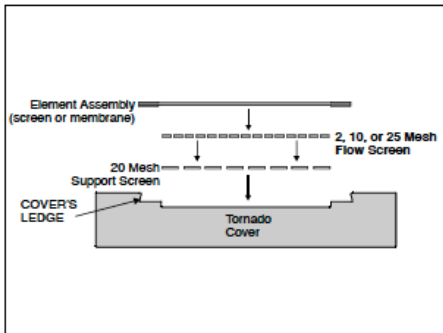

The original stainless steel bolts were lubricated. If necessary, apply a small amount of lube to the lower half of each bolt to ensure they are lubricated. Remove any excess lube from the bolts before installing them.

Restore the sample flow to the Tornado.



NOTE: The element/gasket assembly seal should be replaced each time the Tornado is disassembled.

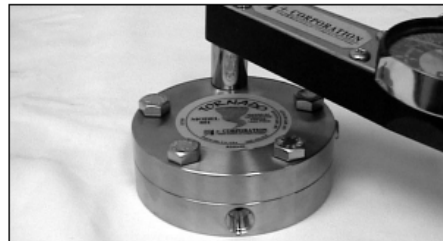

Use the inch-pound torque wrench with the 9/16" socket to tighten each bolt to 120in-lbs. Tighten the bolts in an alternating pattern until all bolts are torqued to 120 in-lbs. If the Tornado does not have a "Reorder Kit #" label, remove the protective backing from one of the enclosed self-adhesive labels and place it on the Tornado.

Only available through authorized
Swagelok sales and service representatives.

Tornado Model 601 Element Replacement Kit Instructions Element Kit Part #601-6XX

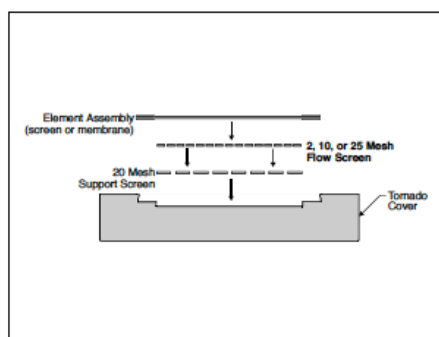
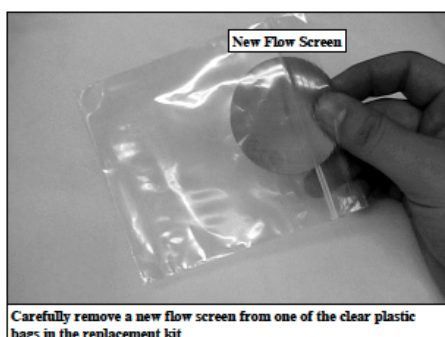
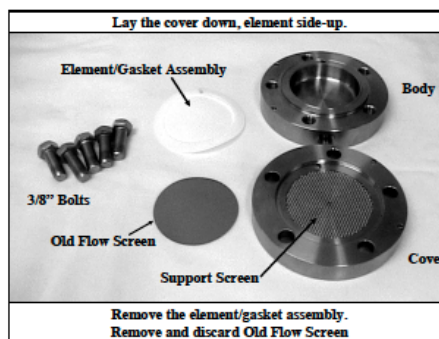
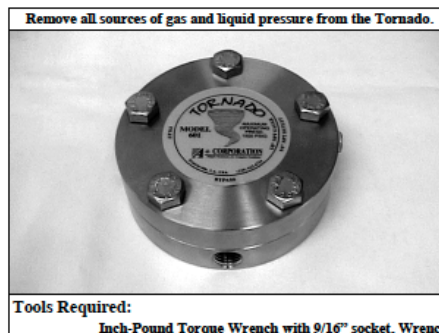
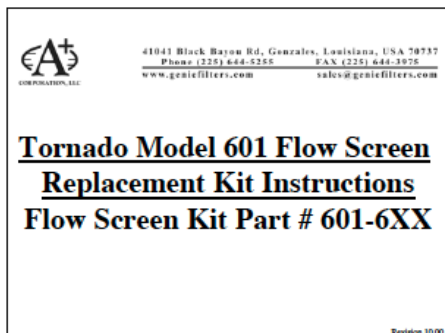

Only available through authorized
Swagelok sales and service representatives.

Tornado Model 601 Element Replacement Kit Instructions Element Kit Part #601-6XX

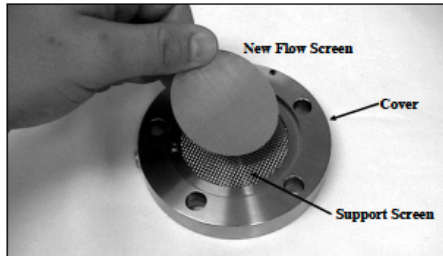

Install the New Flow Screen into the lower cavity of the cover over the support screen. Be sure the edges of the screen are pressed down so that no sharp edges are exposed. The New Flow Screen should have a larger micron size than the element assembly.

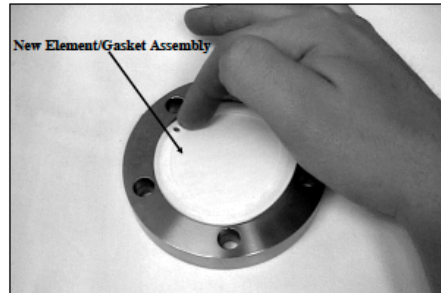

Replace the element/gasket assembly with a new element/gasket (Element/Gasket Assembly Replacement Kit Required).



The original stainless steel bolts were lubricated. If necessary, apply a small amount of lube to the lower half of each bolt to ensure they are lubricated. Remove any excess lube from the bolts before installing them.

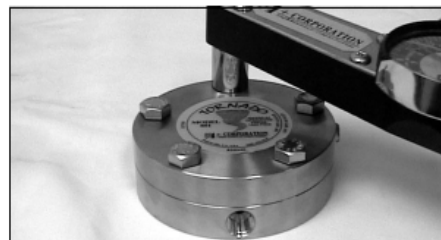

Use the inch-pound torque wrench with the 9/16" socket to tighten each bolt to 120in-lbs. Tighten the bolts in an alternating pattern until all bolts are torqued to 120 in-lbs. If the Tornado does not have a "Reorder Kit #" label, remove the protective backing from one of the enclosed self-adhesive labels and place it on the Tornado.

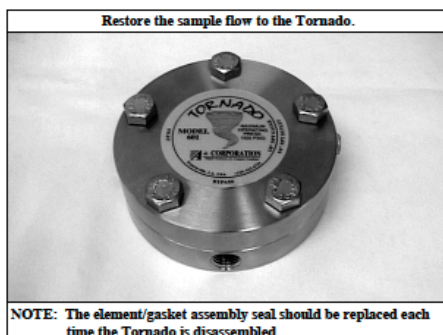

NOTE: The element/gasket assembly seal should be replaced each time the Tornado is disassembled.

SEE OUR WEBSITE FOR OTHER PRODUCTS & LITERATURE
AVAILABLE FROM A+ CORPORATION
www.geniefilters.com

Moisture and Corrosion Control Products - Request Brochure B-MCC

Natural Gas Industry Products (including 410 & Glysoorb) - Request Brochure B-NGI

Analyzer Application Notes - Consult A+ Corporation technical support for specific applications

Series 100 (Gas/Liquid) Genie Membrane Separators - Request Brochure B-100

Series 200 (Liquid/Liquid) Genie Membrane Separators - Request Brochure B-200

Diaphragm Sample Pump - Request Application Note and Installation Instructions

149 Series Membrane Separator Probes (Ambient Air Monitoring Filters) - Request Brochures B-142 and B-143

Only available through authorized
Swagelok sales and service representatives.

Tornado Model 602 Maintenance Instructions



TORNADO
Model 602



Tornado Model 602
Maintenance Instructions

Manufacturing Contact Information
A+ Corporation, LLC *Call for expert product application assistance:*
 41041 Black Bayou Rd. Phone: (225)-644-5255 Website: www.geniefilters.com
 Gonzales, LA 70725 Fax: (225)-644-3975 E-mail: sales@geniefilters.com

Safety Warnings

⚠ Failure to abide by any of the safety warnings below will result in release of fluid at full pipeline pressure and could result in serious injury or death.

* Do not exceed any equipment pressure ratings.

Tools Required

• Foot POUND Torque Wrench with 3/8" socket Wrench



AN ISO 9001:2008 certified company

©2010 A+ Corporation, LLC. All rights reserved.
 SCC-602-5T96-1-InstMaintenance_0409



Only available through authorized Swagelok sales and service representatives.

Tornado Model 602 Maintenance Instructions



Technical Specifications

Maximum pressure rating	1,500 psig
Maximum recommended supply pressure	Lowest possible pressure consistent with application* *Not our design. Pressure rating stated above.
Maximum temperature	300 °F (149 °C)
Minimum Bypass flow rate	1.5 gpm/min
Flow coefficients, Liquid C _v	Inlet to Bypass: 2.7
Port sizes	Inlet, Outlet, & Bypass: 1/2" female NPT
Internal volume	70 cc
Wetted materials	Macrolon parts - 316 stainless steel / NACE compliant All other metal parts: austenitic stainless steel / NACE compliant Sealing material: Kynar®

Dimensions

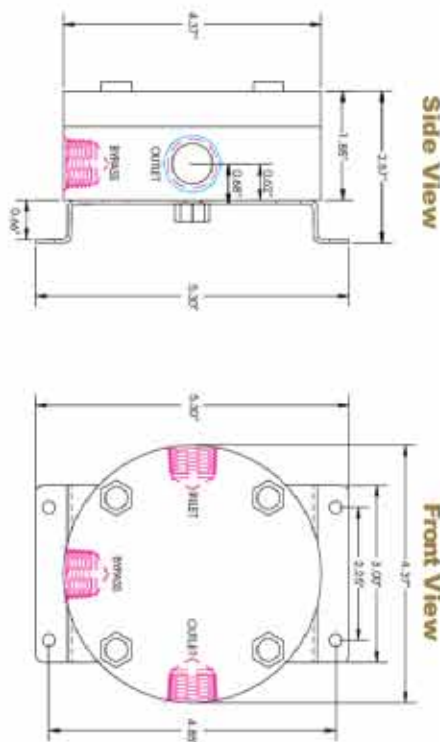

2

©2010 A+ Corporation, LLC. All rights reserved.
SCC-602-5T50-1-maintenance_0409



Only available through authorized Swagelok sales and service representatives.

Tornado Model 602 Maintenance Instructions







Maintenance Instructions

1. Remove all sources of pressure from the Tornado. Use the wrench to remove the four 7/16" bolts and the Tornado cover.
2. Lay the cover down, element side up.
3. Remove and discard the old element and gasket.
4. Remove a new element and gasket from the replacement kit.
5. Place the new element in the cover cavity with the finer (smallest micron) screen facing up. The element has a Teflon binder to hold the 2-instruction composite element assembly together. The Teflon binder also helps to keep the composite element pressed in its cavity during installation.
6. The original stainless steel bolts were lubricated. If necessary, apply a small amount of lube to the lower half of each bolt to ensure they are lubricated. Remove any excess lube from the bolts before installing them. Hold the cover vertically with at least two of the four bolts installed in the palm of your hand. Install the new gasket over the bolts so that it is against the new element (Figure 1).
7. Place the cover with the new element and gasket over the body, and install the remaining bolts into the cover. Use the inch-pound torque wrench with the 5/8" socket to tighten each bolt to 50 Ft-Lbs. Tighten the bolts in an alternating pattern until all bolts are torqued to 50 Ft-Lbs.
8. Restore the sample flow to the Tornado.

NOTE: The gasket should be replaced each time the Tornado 602 is disassembled.



©2010 A+ Corporation, LLC. All rights reserved.
 SCC-002-5156-1 InMaintenance_09100

Only available through authorized Swagelok sales and service representatives.

Tornado Model 602 Maintenance Instructions



Model Numbering & Additional Part Numbers

Your model number is determined by your specific needs. Choose options below:

Element rating	0.5 = 0.5 micron	2 = 2 micron	10 = 10 micron	25 = 25 micron	50 = 50 micron
Kit quantity	Blank = Kit of 5		1 = Kit of 1		
Mounting bracket accessory	Part # = 602-509-SS (sold separately)				

How to build the model number:



How to build the replacement element kit number:



⚠ We cannot recommend specific sealing materials due to the complex nature of sample stream compositions. Temperature and pressure also may be factors. ⚠ Unless specified otherwise, the product will ship with our standard sealing materials and materials of construction stated in the technical specifications section of the corresponding Product Sheet. ⚠ Please refer to www.diaonline.com for sealing material recommendations and advice. It is the user's responsibility to specify the sealing materials and other materials of construction for their application.

GENIE
sampling solutions

Genie® GLUT S™ and Tornado™ are trademarks or registered trademarks of A+ Corporation, LLC. All other referenced trademarks are the property of their respective owners.

Only available through authorized Swagelok sales and service representatives.

Only available through authorized
Swagelok sales and service representatives.

A Swagelok Pre-Engineered Subsystem Fast Loop Module

Warranty Information

Swagelok products are backed by The Swagelok Limited Lifetime Warranty. For a copy, visit swagelok.com or contact your authorized Swagelok representative.

Swagelok, VCO, VCR — TM Swagelok Company
Tornado — TM A Corporation, LLC
Grafoil — TM GrafTech International Holdings, Inc.
© 2011 Swagelok Company
April 2011, R1
MS-13-219

Only available through authorized
Swagelok sales and service representatives.

Swagelok®